

# THE VINTAGE DX7

## SPECIAL EDITION

★ ROM ★

# INSTRUCTION GUIDE

**WARNING!** Lethal voltage can be present and will be exposed when the DX7 case is opened and the unit is plugged in. All service operations, including the installation of LCD's ROM's etc., should be referred to qualified technicians.

TABLE OF CONTENTS

INTRODUCTION.....PAGES 1 - 2

STANDARD ROM & SPECIAL EDITION ROM COMPARISON.....PAGES 2 - 3

HOW TO INSTALL THE SPECIAL EDITION ROM.....PAGES 3 - 7

OPERATIONAL PROCEDURES.....PAGES 7 - 25

BASIC OPERATION.....PAGES 7 - 8

MEMORY SWITCH #1 FUNCTION PARAMETER

        MASTER TUNE.....PAGE 9

MEMORY SWITCH #8 FUNCTION PARAMETER

        MIDI CONTROL.....PAGE 9

        FUNCTION #1, MIDI CHANNEL INFORMATION ON/OFF....PAGES 10 - 13

        FUNCTION #2, MIDI SYSTEM INFORMATION ON/OFF....PAGES 13 - 14

        FUNCTION #3, FC VOLUME INFORMATION ON/OFF....PAGES 14 - 17

        FUNCTION #4, AFTERTOUCH INFORMATION ON/OFF....PAGES 17 - 19

MEMORY SWITCH #10 FUNCTION PARAMETER

        FUNCTION #1, VOICE INITIALIZE.....PAGE 20

        FUNCTION #2, SINGLE FUNCTION INITIALIZE.....PAGES 20 - 22

        FUNCTION #3, ALL FUNCTION INITIALIZE.....PAGES 22 - 23

MEMORY SWITCH #12 FUNCTION PARAMETER

        MIDI RECEIVE FUNCTION.....PAGES 23 - 24

MEMORY SWITCH #13 FUNCTION PARAMETER

        MIDI TRANSMIT FUNCTION.....PAGES 24 - 25

FINAL NOTES.....PAGE 25

FUNCTION JOB TABLE.....PAGES 26 - 28

APPENDIX A 2 ROM MODIFICATION INFORMATION.....PAGES 29 - 31

APPENDIX B TROUBLESHOOTING SECTION.....PAGES 32 - 35

APPENDIX B TROUBLESHOOTING CHART.....PAGES 36 - 40

APPENDIX C INITIALIZED FUNCTION PARAMETER CHART....PAGE 41

SPECIAL EDITION ROM - INTRODUCTION

Thank you for purchasing the SPECIAL EDITION SYSTEM ROM for the Vintage (original) DX7 synthesizer. This INSTRUCTION GUIDE will provide you with the necessary information to both install and operate the SPECIAL EDITION ROM version. It is advisable that you read through this INSTRUCTION GUIDE thoroughly before installing and operating the unit.

It might prove helpful to describe the basic definition and function of a ROM device or IC (Integrated Circuit). The word ROM stands for READ ONLY MEMORY. A ROM is a device with multiple pins, and in the case of the SPECIAL EDITION ROM, it has a total of 28 pins (14 pins per side) as shown in FIGURE 1.

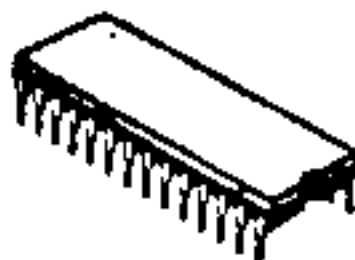

FIGURE 1

Basically a ROM has stored in it a series of instructions and constant values that are used by the computer unit of the instrument. The computer unit of the instrument (in this case the DX7) retrieves instructions from the ROM and performs the necessary tasks in order to operate or implement a particular function. Therefore, by removing the DX7's old ROM and replacing it with the SPECIAL EDITION ROM (that has different instructions stored in it), you can then access new and enhanced functions.

The SPECIAL EDITION ROM was developed to enhance the Performance and MIDI capabilities of the Vintage DX7. The enhanced features of this SPECIAL EDITION ROM include the following:

- (1) FUNCTION PARAMETERS FOR EACH VOICE CAN BE MEMORIZED OR SAVED TO INTERNAL MEMORY OR A RAM CARTRIDGE!
- (2) THE SPECIAL EDITION ROM DISPLAYS THE CURRENT MASTER TUNE SETTING OF THE DX7!
- (3) MIDI CHANNEL INFORMATION ON/OFF FEATURE WHICH ALLOWS YOU TO ENABLE OR DISABLE PROGRAM AND CONTROL CHANGES!
- (4) MIDI SYSTEM INFORMATION ON/OFF FEATURE THAT ALLOWS YOU TO TRANSMIT SYSTEM EXCLUSIVE DATA OF A SINGLE VOICE OR ALL 32 VOICES CONTAINED IN INTERNAL MEMORY!
- (5) INITIALIZATION FEATURE TO INITIALIZE FUNCTION PARAMETERS OF A SINGLE VOICE OR ALL 32 VOICES!

## DX7 SPECIAL EDITION ROM INSTRUCTION GUIDE

- (6) MIDI RECEIVE FEATURE THAT ALLOWS YOU TO SET THE MIDI RECEIVE CHANNEL TO THE "OMNI ON" MODE OR ANY ONE OF 16 MIDI CHANNELS!
- (7) MIDI TRANSMIT FEATURE WHICH ALLOWS YOU TO SET THE MIDI TRANSMIT CHANNEL TO ANY ONE OF THE 16 MIDI CHANNELS!
- (8) AFTERTOUCH ON/OFF FEATURE THAT ALLOWS YOU TO SELECT WHETHER YOU WANT TO TRANSMIT, OR NOT TRANSMIT, MIDI AFTERTOUCH INFORMATION. THIS AFTERTOUCH ON/OFF PARAMETER CAN BE MEMORIZED OR SAVED FOR EACH VOICE! ..AND...
- (9) MAIN VOLUME TRANSMIT FEATURE WHICH ALLOWS YOU TO TRANSMIT MIDI VOLUME INFORMATION BY UTILIZING THE MODULATION FOOT CONTROLLER INPUT. THIS PARAMETER CAN ALSO BE MEMORIZED OR SAVED FOR EACH VOICE!

### STANDARD ROM & SPECIAL EDITION ROM COMPARISON

The following section will review the fundamental differences between the Standard ROM and the SPECIAL EDITION ROM. As previously mentioned, the SPECIAL EDITION ROM can memorize specific FUNCTION PARAMETERS for each voice, where the Standard ROM did not. More specifically, the SPECIAL EDITION ROM can memorize FUNCTION PARAMETERS represented by switches 2 through 7 and switches 17 through 32 of the DX7's front control panel. Also, two FUNCTION PARAMETERS of switch 8 can be memorized. Therefore, the main differences between the ROM versions exists in the FUNCTION MODE of the DX7. Only the FUNCTIONS that are different will be described. All other FUNCTIONS of this SPECIAL EDITION ROM are the same as the Standard ROM. FUNCTION switches 1, 8, 10, 12, and 13 of the SPECIAL EDITION ROM version operate differently than the Standard ROM and their operational characteristics will be described in more detail later. The basic differences in these FUNCTIONS are as follows:

#### MEMORY SWITCH #1 FUNCTION PARAMETER - MASTER TUNE ADJ (ADJUST)

With the Standard ROM, only the message "MASTER TUNE ADJ" is displayed on the LCD display and when moving the DATA ENTRY slider the pitch will vary, but it will not be displayed.

The SPECIAL EDITION ROM displays the MASTER TUNE message plus the current value of the MASTER TUNE setting. When the DATA ENTRY slider is moved the pitch will vary and it will also be displayed, for example, Master Tune = 0.

#### MEMORY SWITCH #8 FUNCTION PARAMETER - MIDI CONTROL

With the Standard ROM, the FUNCTIONS of switch #8 are; (1) the MIDI RECEIVE CHANNEL FUNCTION, (2) the SYSTEM AVAILABLE/UNAVAILABLE FUNCTION, and (3), when the SYSTEM AVAILABLE FUNCTION is selected, the MIDI TRANSMIT FUNCTION.

The SPECIAL EDITION ROM has some additional functions associated with the #8 FUNCTION SWITCH. With the SPECIAL EDITION ROM, the FUNCTIONS of this switch are as follows; (1) the MIDI CHANNEL INFORMATION ON/OFF FUNCTION which allows you to select whether or not you want to RECEIVE and TRANSMIT, PROGRAM and CONTROL CHANGES., (2) the MIDI SYSTEM INFORMATION ON/OFF FUNCTION which is the same as the SYSTEM AVAILABLE/UNAVAILABLE FUNCTION and the MIDI TRANSMIT FUNCTION., (3) the FC (Foot Controller) VOLUME ON/OFF FUNCTION that allows you to utilize the Foot Controller modulation input to transmit MIDI VOLUME INFORMATION (this function is programmable for each voice)., and (4) the AFTERTOUCH ON/OFF FUNCTION which allows you to transmit AFTERTOUCH INFORMATION (this function is also programmable for each voice).

MEMORY SWITCH #10 FUNCTION PARAMETER - INITIALIZE FUNCTION

With the Standard ROM, this FUNCTION PARAMETER is used for the VOICE INITIALIZE FUNCTION which sets or initializes VOICE PARAMETERS to specific conditions in order to provide a starting point for voice programming purposes.

The SPECIAL EDITION ROM has three FUNCTIONS associated with the #10 switch and they are; (1) the VOICE INITIALIZE FUNCTION that performs the same function as the Standard ROM VOICE INITIALIZE FUNCTION., (2) the SINGLE FUNCTION INITIALIZE JOB which sets the programmable FUNCTION PARAMETERS of a SINGLE VOICE to specific conditions, thus providing a starting point for EDITING purposes., and (3) the ALL FUNCTION INITIALIZE FUNCTION that sets the programmable FUNCTION PARAMETERS of all 32 VOICES to the same specific conditions.

MEMORY SWITCH #12 FUNCTION PARAMETER - MIDI RECEIVE FUNCTION

The Standard ROM has no function assigned to SWITCH #12. However, with the SPECIAL EDITION ROM, SWITCH #12 is assigned to the MIDI RECEIVE FUNCTION. This function allows you to set the MIDI RECEIVE CHANNEL of the DX7 to the OMNI ON MODE or any one of the 16 different MIDI channels, 1 through 16. Remember the OMNI ON MODE will allow the DX7 to receive all incoming MIDI information, regardless of the MIDI channel number.

MEMORY SWITCH #13 FUNCTION PARAMETER - MIDI TRANSMIT FUNCTION

The Standard ROM also has no function assigned to SWITCH #13. The SPECIAL EDITION ROM utilizes SWITCH #13 to set the MIDI TRANSMIT CHANNEL to any one of the 16 different MIDI channels, 1 through 16.

HOW TO INSTALL THE SPECIAL EDITION ROM

Before attempting to install the SPECIAL EDITION ROM, please read the following Installation Instructions thoroughly and then proceed with the installation. Installation of the SPECIAL

## DX7 SPECIAL EDITION ROM INSTRUCTION GUIDE

EDITION ROM requires a particular level of knowledge. Therefore, if the instruction seem unclear and you are NOT familiar or experienced with handling and inserting electronic components, then the installation of the SPECIAL EDITION ROM should be performed by a Qualified Service Technician. Remember that in order to prevent any accidental circumstances resulting in the loss of the DX7 Voices stored in its memory, you should back-up or make a copy of the Voices before installing the ROM.

Also, if you find that your DX7 has 2 SYSTEM ROM ICs (identified by IC designations IC14 & IC15 on the DM circuit board) then your unit needs further modification before installing the SPECIAL EDITION ROM. This modification will allow you to use a single ROM IC instead of 2 ROM ICs and it is only necessary for a few very early production models. In almost all cases this modification will not be necessary. Serial numbers of applicable DX7 units are given in APPENDIX A, however, some units may have already been modified. When you gain access to the internal circuitry of the DX7, you will be able to verify whether or not you need to have this modification done. If your unit has only one ROM IC, which is inserted into the IC14 socket, and IC15 is NOT present then the modification is NOT necessary (in other words, NO IC15 - NO MODIFICATION). If there are two ROM ICs, one in the IC14 socket and one in the IC15 socket then the modification is required. If you do not have experience in the area of soldering and handling electronic components then this modification and the SPECIAL EDITION ROM installation should be performed by a Qualified Service Technician. Once again, if your unit requires this modification REFER TO APPENDIX A, Page 29.

In order to prepare the DX7 for the SPECIAL EDITION ROM installation, the only tools you will need are;

- (1) A PHILLIPS TYPE SCREW DRIVER ..and...
- (2) A SMALL FLAT-BLADE SCREW DRIVER.

If your DX7 needs further modification as previously mentioned, you will need additional tools and they are;

- (1) A SOLDERING IRON
- (2) A SOLDER VACUUM OR SOLDER WICK
- (3) SOLDER ..and...
- (4) NEEDLE-NOSE PLIERS.

After obtaining the proper tools and performing any other modification preparations, you can then proceed with the SPECIAL EDITION ROM installation by following the STEPS given below:

- (1) In order to avoid the possibility of electrical shock and any accidental damage to the unit, make sure that

## DX7 SPECIAL EDITION ROM INSTRUCTION GUIDE

the power switch is TURNED OFF and the power cord is unplugged. Also disconnect any MIDI, OUTPUT or FOOT CONTROLLER cables connected to the unit.

- (2) Remove the 5 Phillips-Head screws that secure the DX7's front control panel as shown in FIGURE 2. It should also be noted that the screw designated with the letter "B" (located next to the power switch) is shorter than the other screws. Please make sure that this screw is used at the same location when securing the front panel after installation of the SPECIAL EDITION ROM is complete!

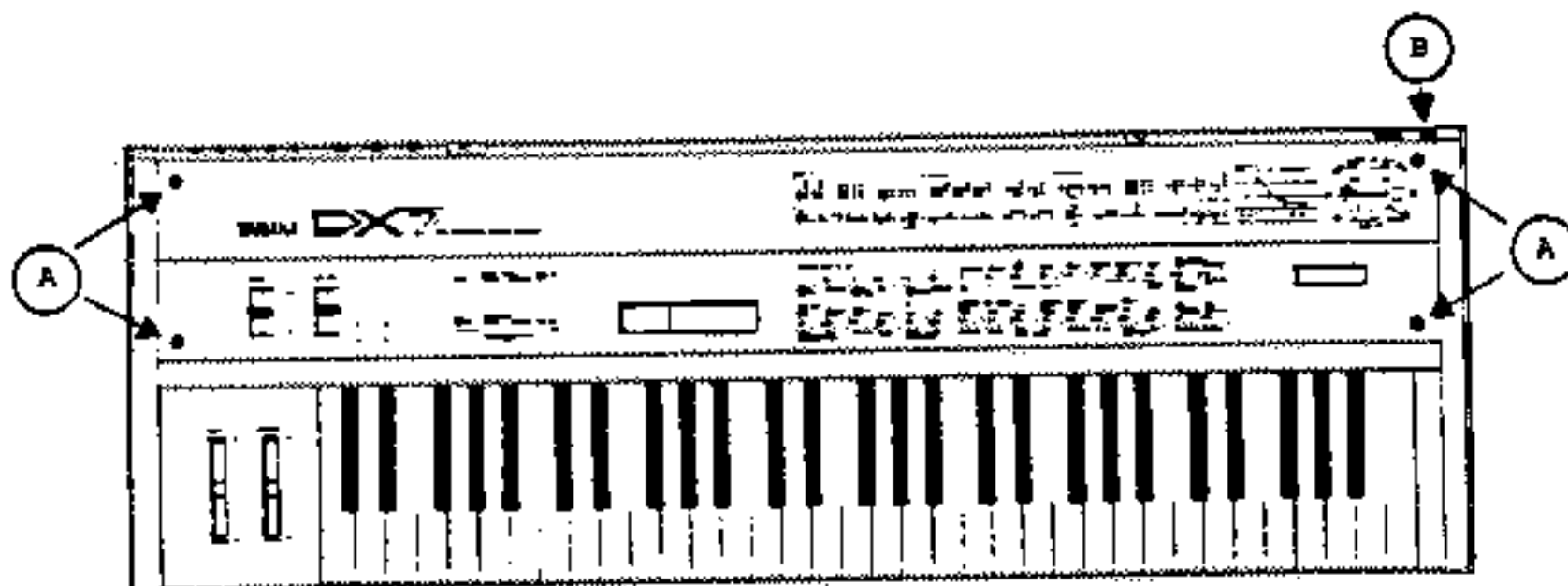

<u>DESIGNATION</u>	<u>QUANTITY</u>	<u>TYPE &amp; SIZE</u>
A	(4)	PHILLIPS HEAD/TAPPING TYPE (SIZE 4X16mm)
B	(1)	PHILLIPS HEAD/TAPPING TYPE (SIZE 4X8mm)

FIGURE 2

- (3) Carefully lift-up the edge of the DX7's front control panel, closest to the keyboard and open it all the way until it is resting against the back edge of the DX7 case as shown in Figure 3 on the next page.
- (4) Locate IC14, the ROM IC. IC14 is located near the center of the Main Circuit board (the DM board), also shown in FIGURE 3. At this point you can verify whether or not your unit requires further modification before installing the SPECIAL EDITION ROM. Remember, NO IC15, then NO modification is necessary. If IC15 is present then your DX7 needs modification before proceeding and you should refer to APPENDIX A on Page 29. After completion of the modification proceed with Step 5. If NO modification is required then go to Step 5.

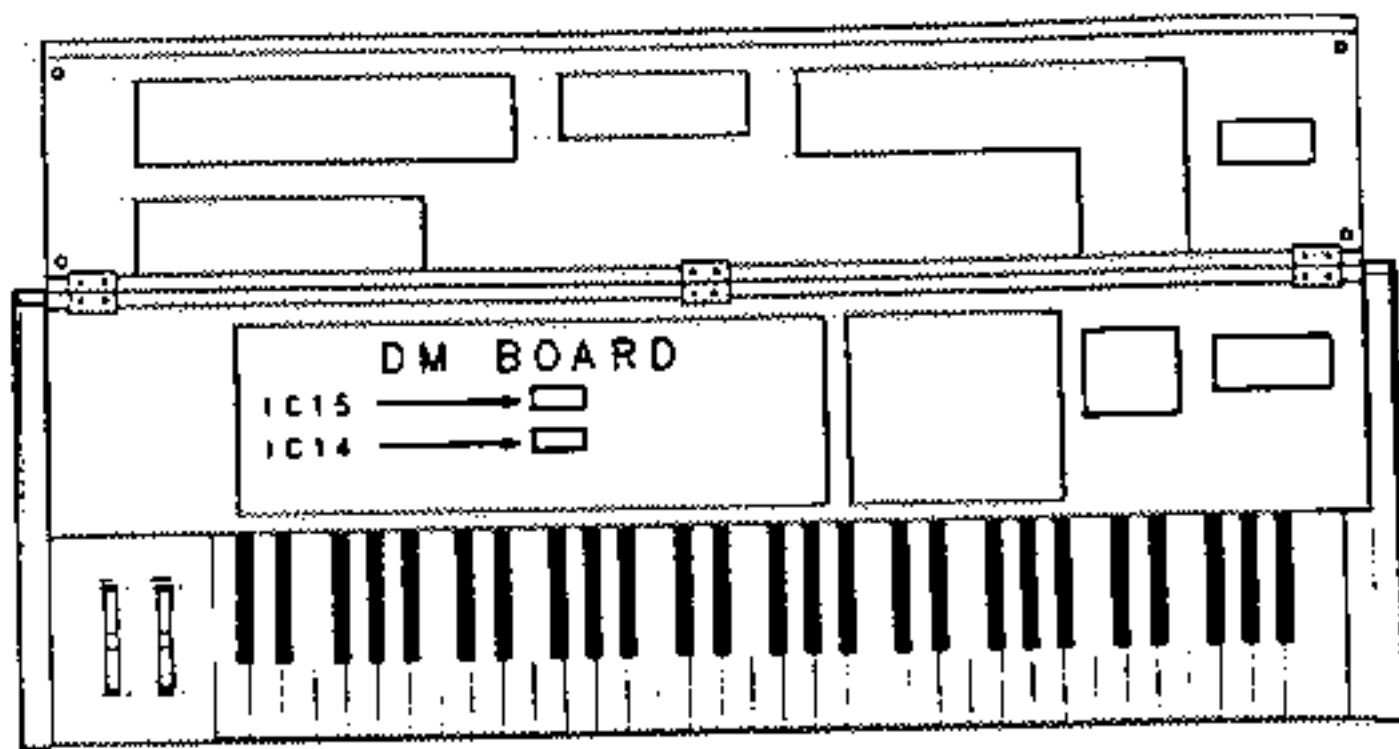

FIGURE 3

- (5) Before removing IC14 from its socket, note the location or direction of the notch of IC14. As you are facing the unit, the notch of IC14 should be positioned so that it points to the right hand side of the DX7. Now carefully place the blade of a small flat-blade screwdriver between the IC14 and its socket. Gently pry up IC14, first on one side (SIDE A) and then on the other (SIDE B) as shown in FIGURE 4. Repeat the process until IC14 is freed from the socket and put it aside.

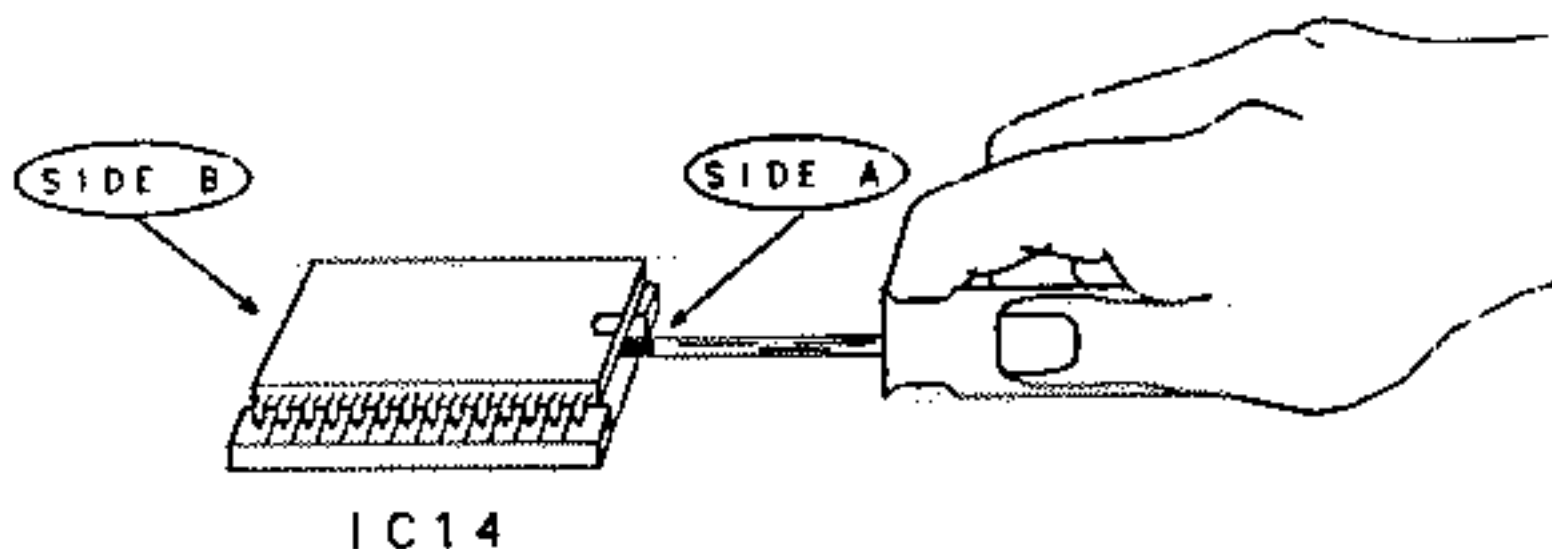

FIGURE 4



## DX7 SPECIAL EDITION ROM INSTRUCTION GUIDE

- (6) Now the SPECIAL EDITION ROM can be inserted into the IC14 socket. Before inserting the SPECIAL EDITION ROM take note of the direction of the notch. The notch of the SPECIAL EDITION ROM should also face or point in the direction of the right side of the DX7. Also make sure the pins of the SPECIAL EDITION ROM are all aligned with holes of the IC14 socket. If some pins are not in the proper position for inserting, then before inserting the SPECIAL EDITION ROM, carefully bend the pins to their proper position. Once the notch and pins of the SPECIAL EDITION ROM are properly positioned then carefully insert the ROM IC. Inspect your work thoroughly to make sure that no pins have been bent under or damaged during insertion.
- (7) Make a quick operational test of the DX7 by closing the front control panel and plugging the power cord of the DX7 into an AC outlet. Turn on the DX7, the LCD display should initially read;

WELCOME TO DX7  
SPECIAL EDITION

..and...then the LCD display should indicate the previous mode or condition that was last set-up on the front control panel. Make sure that you can select various voices and play the keyboard to verify that the DX7 produces a sound when an amplifier or pair of headphones is connected to the unit. If the LCD display does not indicate the above conditions, or the DX7 does not produce a sound, then turn OFF the power of the DX7 and refer to the TROUBLESHOOTING SECTION found in APPENDIX B on Page 32.

- (B) Once you have verified the basic operation of the DX7 then turn off the power and reinstall the 5 front control panel retaining screws. Remember the shorter screw is to be reinstalled next to the power switch.

Now you are ready too explore the advantages of the SPECIAL EDITION ROM!!

### OPERATIONAL PROCEDURES

In this section the Operational Procedures of the SPECIAL EDITION ROM will be described in detail. It may be helpful to follow along with the DX7 turned ON, so that you can go through the procedures of implementing the additional functions of the SPECIAL EDITION ROM. Only the additional functions will be described in detail. The FUNCTION JOB TABLE on PAGES 26 to 28 will provide you with an overall picture of all the Functions of the DX7.

Referring to FIGURE 5 on the next page, the procedure for

initiating the FUNCTION MODE of the DX7 is the same as before. Remember, the FUNCTION MODE is activated by pressing the FUNCTION SWITCH to the LEFT of the LCD display, then you can implement the desired FUNCTION by pressing the appropriate MEMORY SWITCH to the RIGHT of the LCD display. In almost all cases the designation written below each MEMORY SWITCH (in light brown lettering) identifies the FUNCTION PARAMETER of that switch. However, in some cases the MEMORY SWITCH will not have a designation identifying the FUNCTION PARAMETER. The SPECIAL EDITION RDM has some MEMORY SWITCHES that have MULTIPLE FUNCTION PARAMETERS. Therefore, when you press the MEMORY SWITCH again you can call up a new FUNCTION PARAMETER. As you know the DATA ENTRY SLIDER or DATA ENTRY SWITCHES are used to change the FUNCTION PARAMETERS.

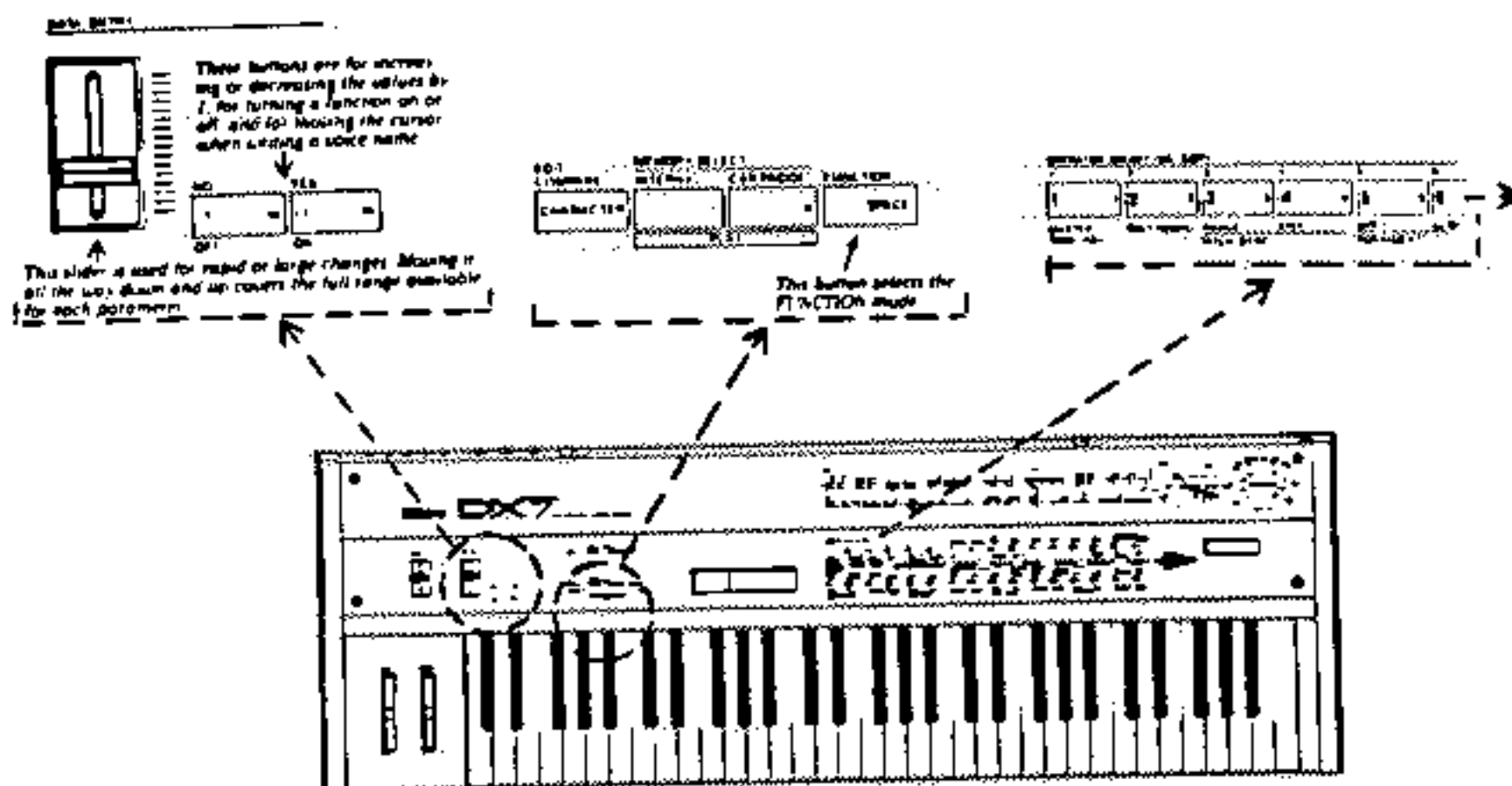

FIGURE 5

Before proceeding you should verify the present condition of each FUNCTION. Sometimes when a RDM IC is changed, some of the FUNCTIONS may be inadvertently set to illegal or invalid conditions. This is the reason for verifying the conditions of each FUNCTION. Therefore, go through each FUNCTION beginning with the MASTER TUNE FUNCTION and check the LCD display. If the display does not indicate the proper condition or has strange characters shown in the display, simply move the DATA ENTRY control to MINIMUM, then to MAXIMUM and then back to the MINIMUM setting to reset the FUNCTION. Once the FUNCTION has been reset you may wish to set it to the condition that you require.

MEMORY SWITCH #1 FUNCTION PARAMETER - MASTER TUNE

The first FUNCTION to be described is the MASTER TUNE FUNCTION, please refer to FIGURE 6. By pressing the FUNCTION SWITCH and then pressing the #1 MEMORY SWITCH, you can activate the MASTER TUNE FUNCTION of the DX7. The SPECIAL EDITION ROM will display the current MASTER TUNE setting. Moving the DATA ENTRY SLIDER or DATA ENTRY SWITCHES will change the display in 1 UNIT increments from -64 to +63. Each increment represents a 1.17 cent change in PITCH, therefore, you can vary the PITCH 75 cents (3/4 of a SEMITONE) either LOWER (represented by the - sign) or HIGHER (represented by the + sign) in PITCH. Remember you can utilize the DATA ENTRY SLIDER as a course adjustment of the PITCH and the DATA ENTRY SWITCHES as a fine adjustment.

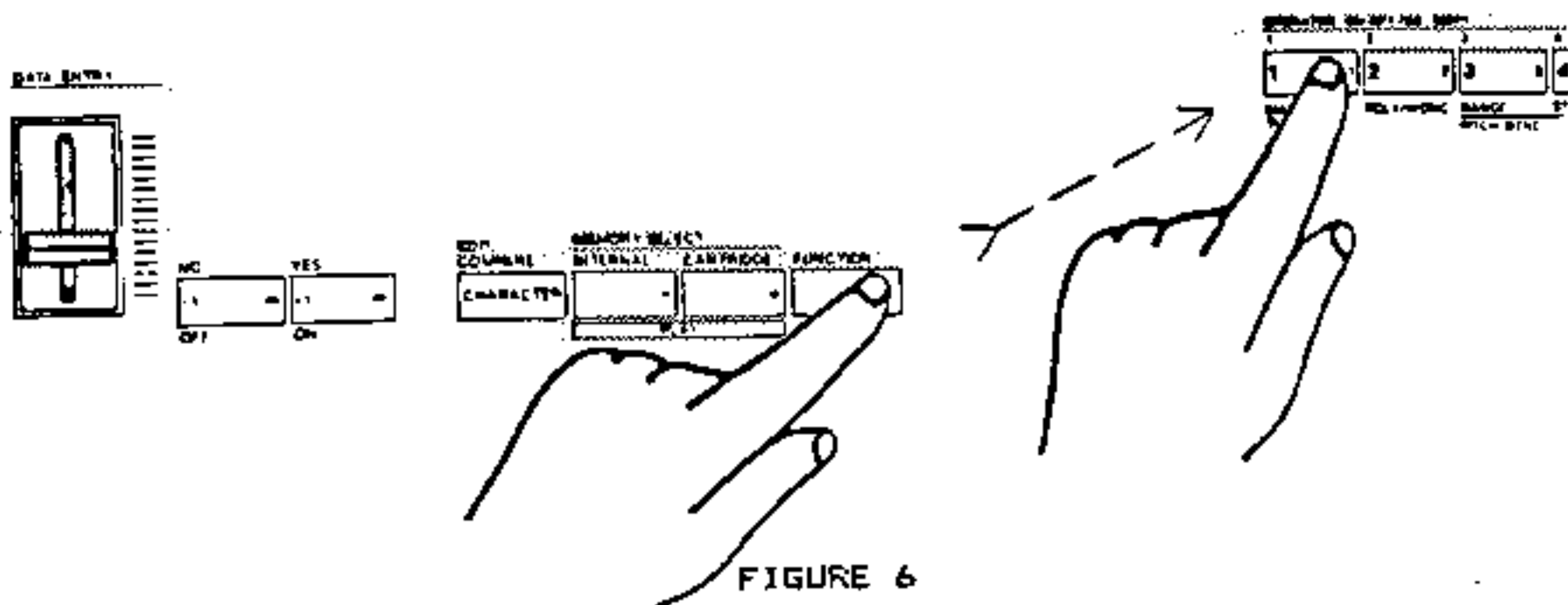

FIGURE 6

If you adjust the PITCH so that the LCD display reads;

MASTER TUNE = 0

then the DX7 tuning is set so that the A3 note or pitch has a frequency of 440 Hertz. The MASTER TUNE setting or FUNCTION PARAMETER is common type data and therefore, you cannot save this tuning data as FUNCTION DATA. In other words, MASTER TUNE data is common to all voices and it cannot be memorized per voices, just as it was with the Original ROM Version.

MEMORY SWITCH #8 FUNCTION PARAMETER - MIDI CONTROL

The next set of FUNCTIONS to describe are the MIDI CONTROL FUNCTIONS of MEMORY SWITCH #8. If you are still in the FUNCTION MODE, simply press MEMORY SWITCH #8 to implement the MIDI CONTROL FUNCTIONS. If you are not in the FUNCTION MODE press the FUNCTION SWITCH to the left of the LCD Display and then MEMORY SWITCH #8. As previously mentioned, the SPECIAL EDITION ROM has four FUNCTIONS associated with this switch; (1) the MIDI CHANNEL INFORMATION ON/OFF FUNCTION, (2) the MIDI SYSTEM INFORMATION ON/OFF FUNCTION, (3) the FC (Foot Controller) VOLUME ON/OFF FUNCTION, and (4) the AFTERTOUCH ON/OFF FUNCTION.

MEMORY SWITCH #8 - FUNCTION #1, MIDI CHANNEL INFORMATION ON/OFF

On the first press of MEMORY SWITCH #8, the LCD Display will indicate that you have implemented the MIDI CHANNEL INFORMATION ON/OFF FUNCTION by displaying the message shown in FIGURE 7. FIGURE 7 also shows the condition of the MIDI CHANNEL INFORMATION FUNCTION in the OFF condition.

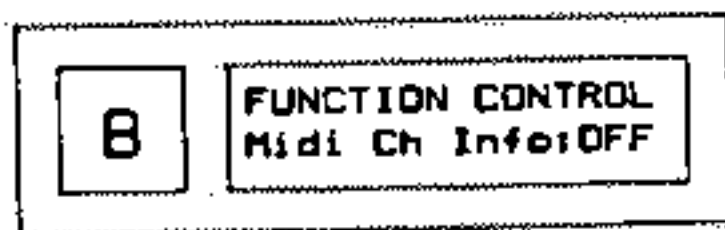

FIGURE 7

FIGURE 8 shows that in order to select the MIDI CHANNEL INFORMATION to the ON condition, simply move the DATA ENTRY SLIDER to the MAXIMUM position or press the YES/+1/ON SWITCH. The LCD Display will then indicate that the MIDI CHANNEL INFORMATION FUNCTION is set to the ON condition.

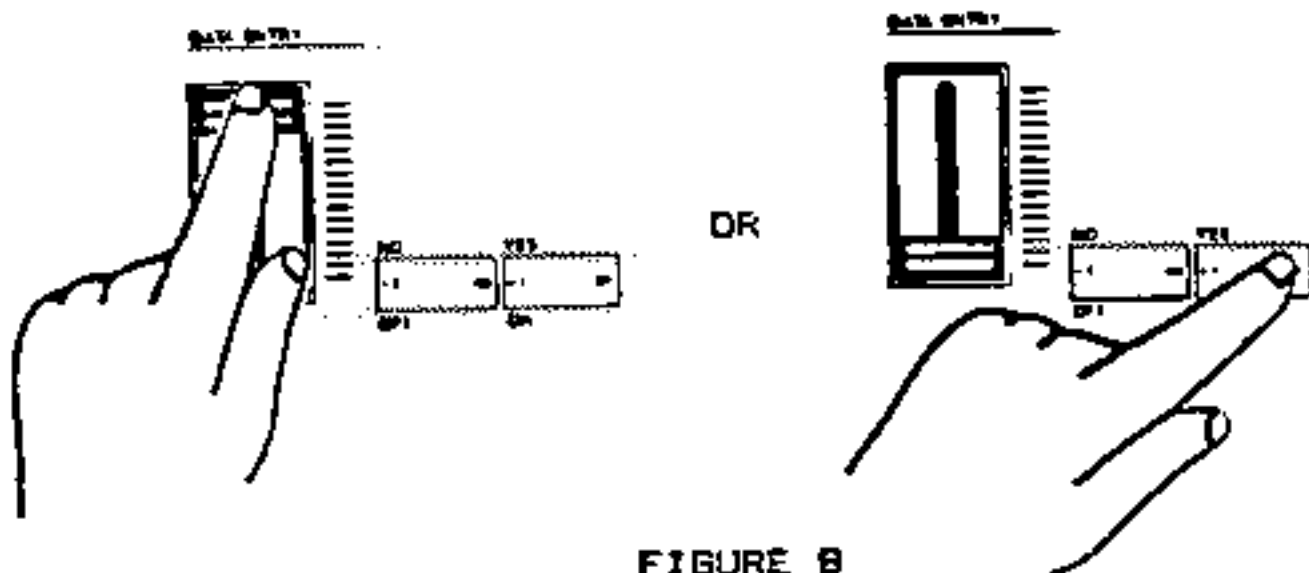

FIGURE 8

In order to select the MIDI CHANNEL INFORMATION FUNCTION to the OFF condition move the DATA ENTRY SLIDER to the MINIMUM position or press the NO/-1/OFF switch as shown in FIGURE 9. The LCD Display will indicate the OFF condition of the MIDI CHANNEL INFORMATION FUNCTION.

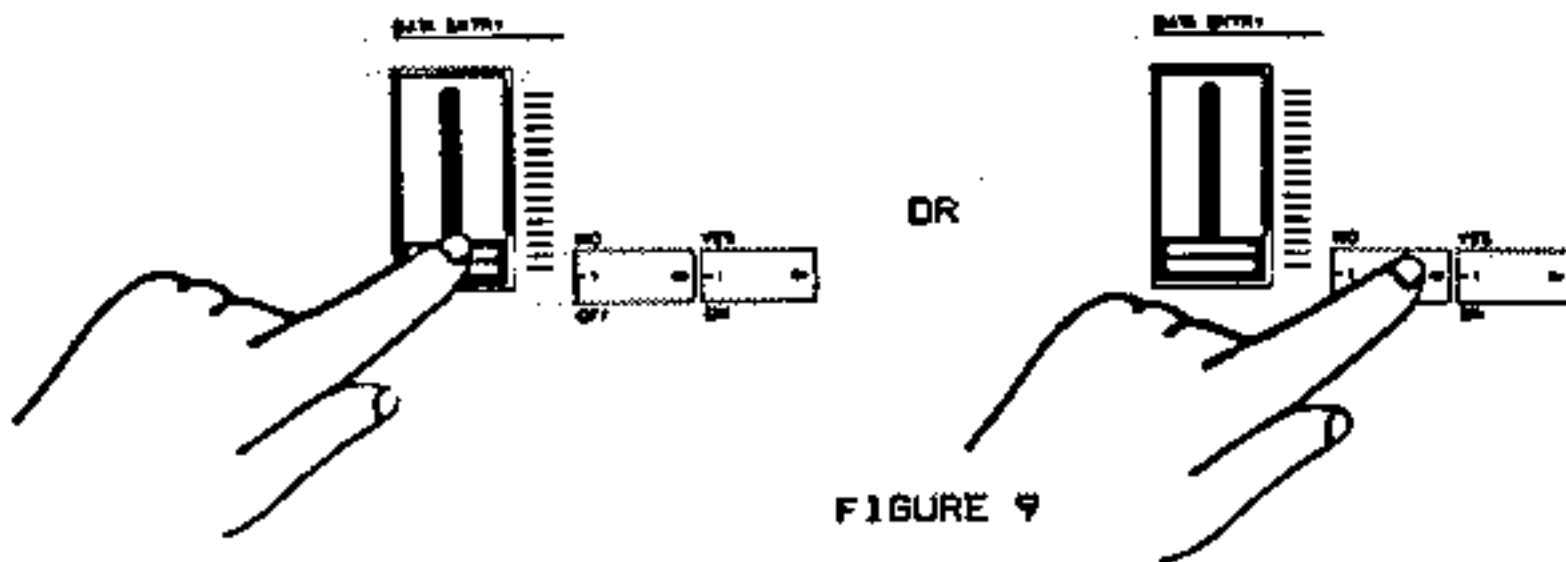
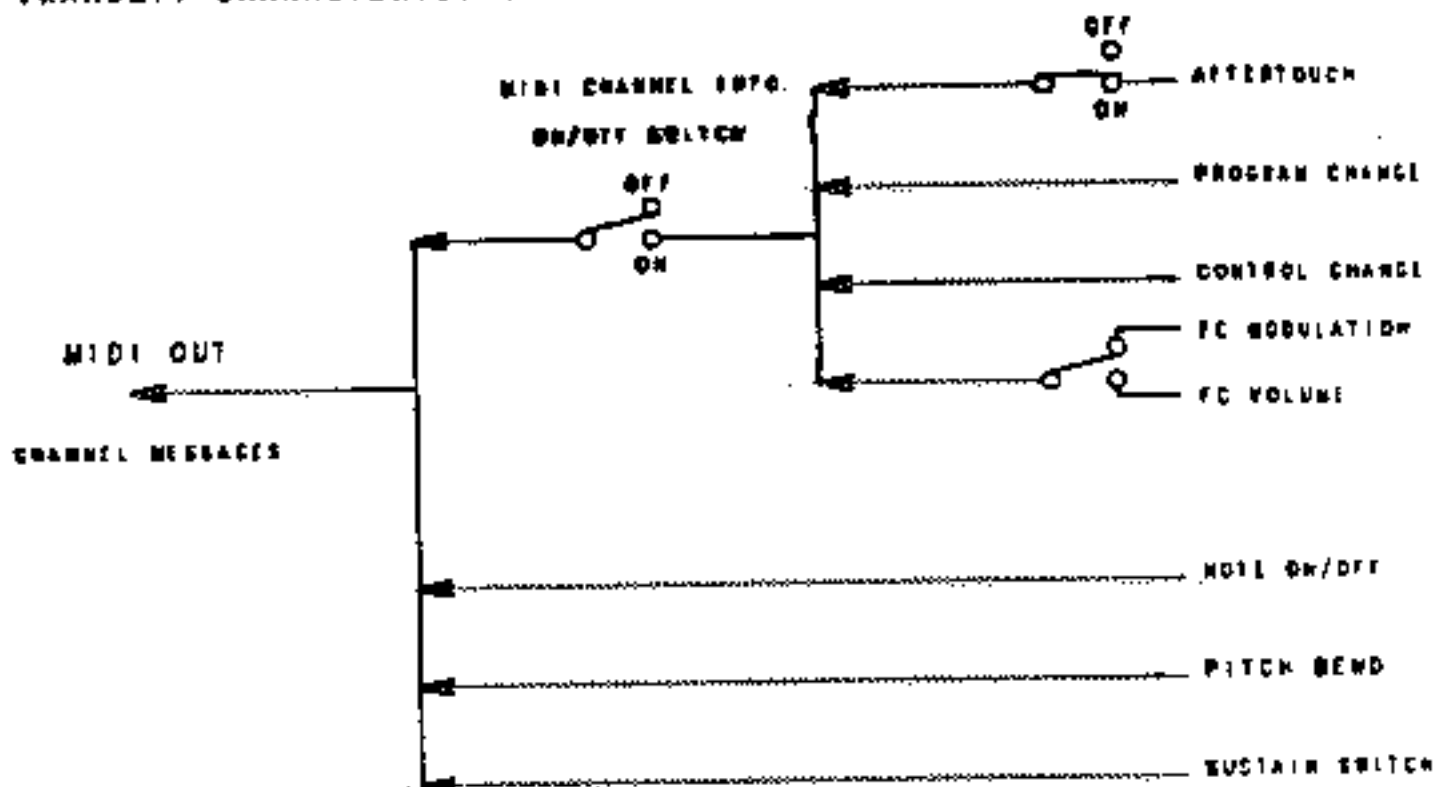

FIGURE 9

# DX7 SPECIAL EDITION ROM INSTRUCTION GUIDE

FIGURE 10 shows diagrams of the TRANSMIT and RECEIVE characteristics when the MIDI CHANNEL INFORMATION FUNCTION is set to the OFF condition. In the OFF condition the DX7 can TRANSMIT and RECEIVE, NOTE ON/OFF MIDI MESSAGES, PITCH BEND MIDI MESSAGES, and SUSTAIN CONTROL MIDI MESSAGES. However, the DX7 will NOT TRANSMIT or RECEIVE, AFTERTOUCH MESSAGES, PROGRAM CHANGE MESSAGES, CONTROL CHANGE MESSAGES, FC MODULATION MESSAGES, and CONTROL CHANGE MESSAGES EXCEPT FOR SUSTAIN CONTROL.

## TRANSMIT CHARACTERISTICS WHEN CHANNEL INFORMATION FUNCTION IS OFF



## RECEIVE CHARACTERISTICS WHEN CHANNEL INFORMATION FUNCTION IS OFF

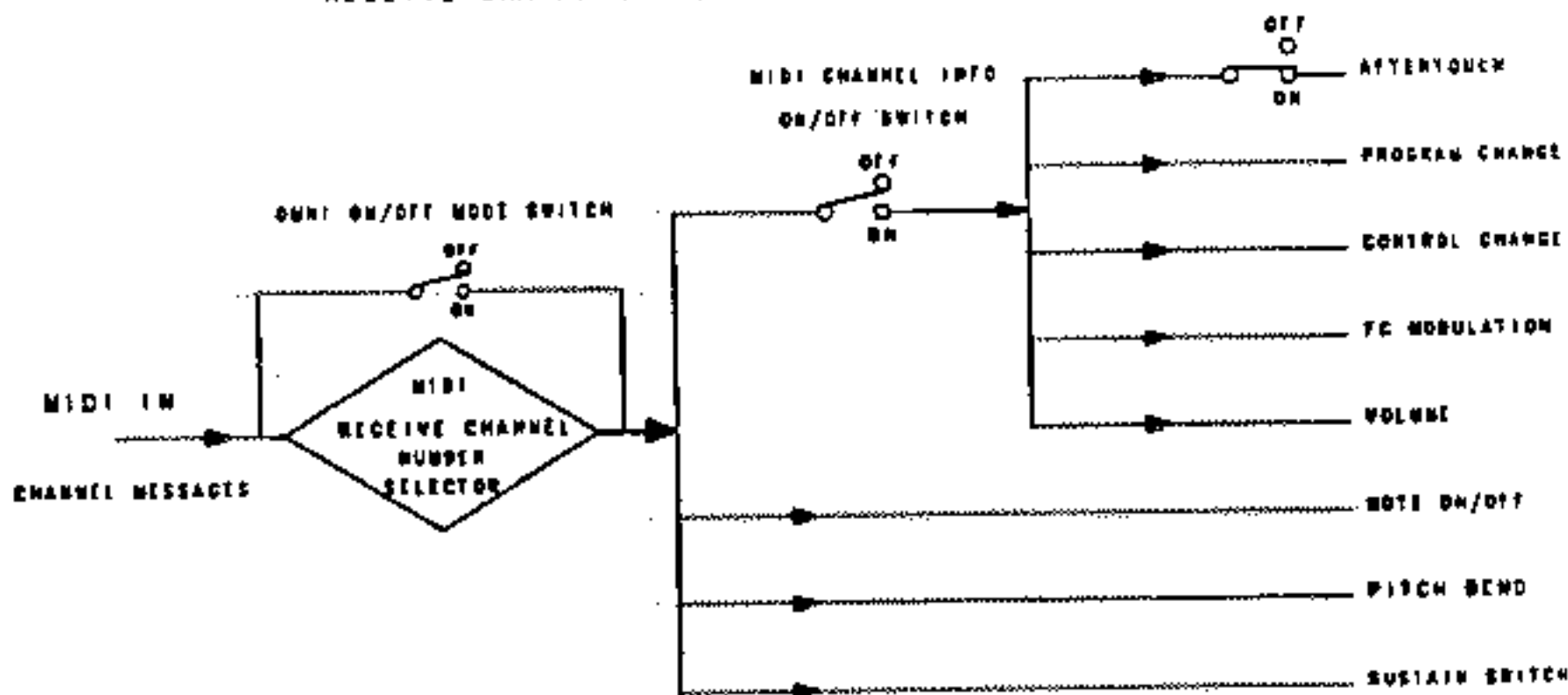
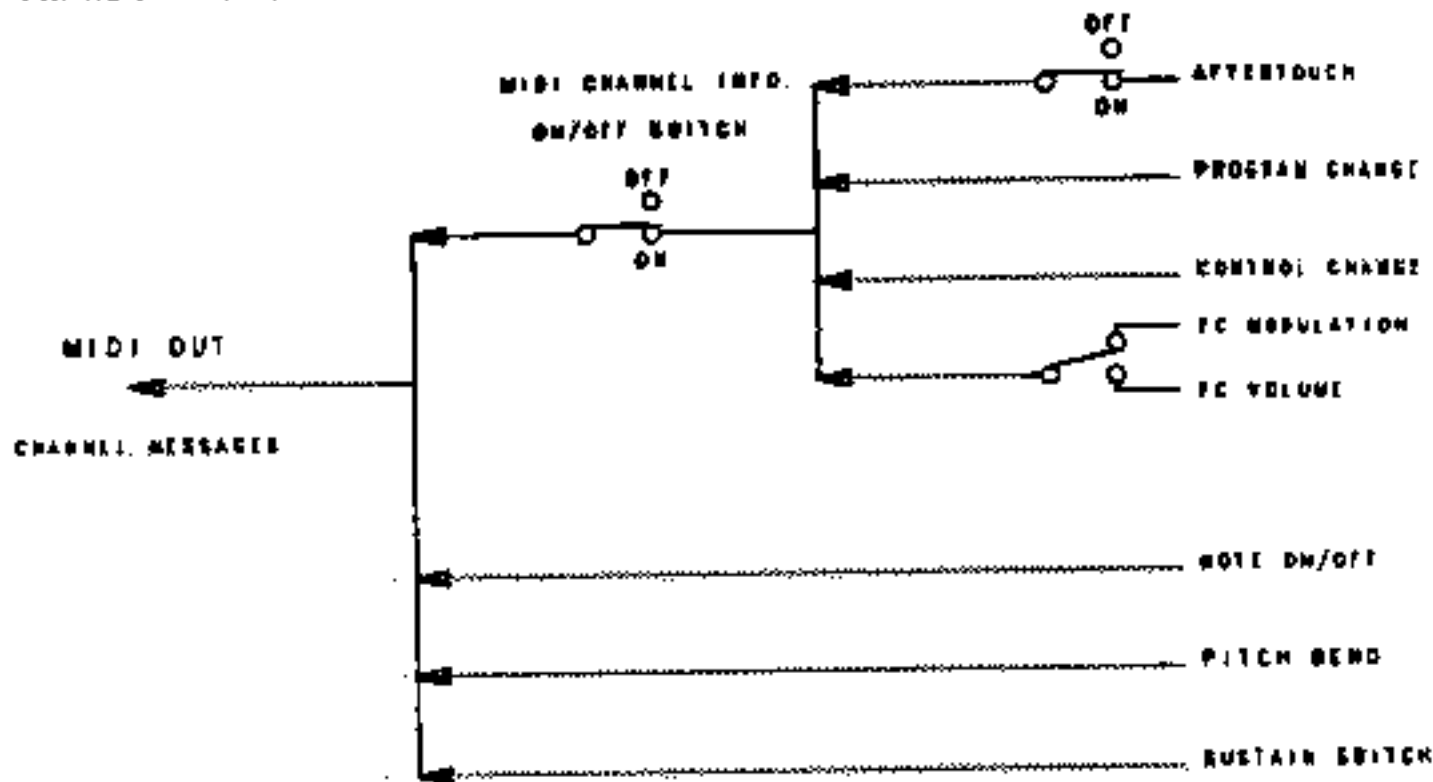

FIGURE 10

# DX7 SPECIAL EDITION RDM INSTRUCTION GUIDE

When the MIDI CHANNEL INFORMATION FUNCTION is set to the ON condition as shown in the TRANSMIT and RECEIVE diagrams of FIGURE 11, all the MIDI MESSAGES will be capable of being TRANSMITTED and RECEIVED by the DX7. However, the TRANSMISSION and RECEPTION of AFTERTOUCH and FC or FOOT CONTROLLER MESSAGES will naturally depend upon the conditions of their associated switches. Switch conditions shown in FIGURE 11, indicate that AFTERTOUCH and MODULATION MESSAGES can be both TRANSMITTED and RECEIVED.

## TRANSMIT CHARACTERISTICS WHEN CHANNEL INFORMATION FUNCTION IS ON



## RECEIVE CHARACTERISTICS WHEN CHANNEL INFORMATION FUNCTION IS ON

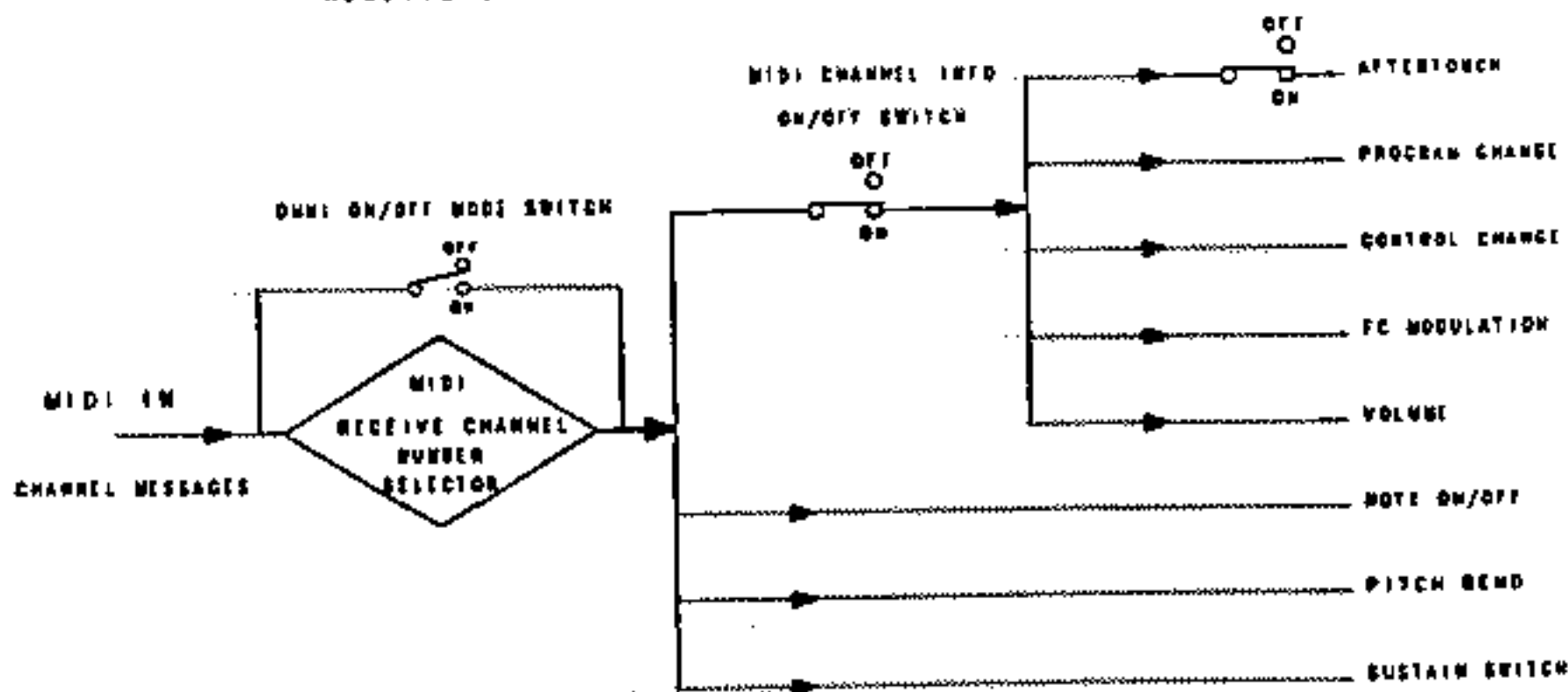

FIGURE 11

The MIDI CHANNEL INFORMATION ON/OFF FUNCTION is a GLOBAL FUNCTION. In other words, it is not a FUNCTION PARAMETER that is programmable per voice. When you select the particular condition, for example the ON condition, it allows the TRANSMISSION and RECEPTION of MIDI MESSAGES for all the voices.

### MEMORY SWITCH #8 - FUNCTION #2, MIDI SYSTEM INFORMATION ON/OFF

By pressing MEMORY SWITCH #8 a second time you can access the second FUNCTION of this switch which is the MIDI SYSTEM INFORMATION ON/OFF FUNCTION. The LCD Display will indicate the MIDI SYSTEM INFORMATION ON/OFF FUNCTION as shown below. In this example, the MIDI SYSTEM INFORMATION ON/OFF FUNCTION is set to the OFF condition.

FUNCTION CONTROL  
Midi Sy Info: OFF

Like the previously described FUNCTION, you can set the MIDI SYSTEM INFORMATION ON/OFF FUNCTION to the ON condition by moving the DATA ENTRY SLIDER to the MAXIMUM position or press the YES/+1/ON SWITCH. The LCD Display will then read;

FUNCTION CONTROL  
Midi Sy Info: ON

With the MIDI SYSTEM INFORMATION FUNCTION "ON", it will allow you to TRANSMIT the PARAMETERS of a SINGLE VOICE or the PARAMETERS of all 32 INTERNAL VOICES out the MIDI OUTPUT. Therefore these PARAMETERS can be sent, for example, to another DX7 or computer. It should be noted that when you transmit a SINGLE VOICE, both VOICE PARAMETERS and FUNCTION PARAMETERS are sent, however, when you transmit all 32 VOICES, only VOICE PARAMETERS are sent, FUNCTION PARAMETERS ARE NOT TRANSMITTED. Also when using the DX7 with the CX5M Computer and the YRM-103 or the YRM-304 DX7 VOICING PROGRAMS, the MIDI SYSTEM INFORMATION ON/OFF FUNCTION must be manually set to the "ON" condition. The DX7 VOICING PROGRAMS will no longer set this FUNCTION to the "ON" condition automatically.

MIDI SYSTEM INFORMATION for a SINGLE VOICE is TRANSMITTED by performing the following procedures:

- (1) Set the MIDI SYSTEM INFORMATION FUNCTION to the "ON" condition.
- (2) Press the INTERNAL MEMORY SELECT switch as shown in FIGURE 12.

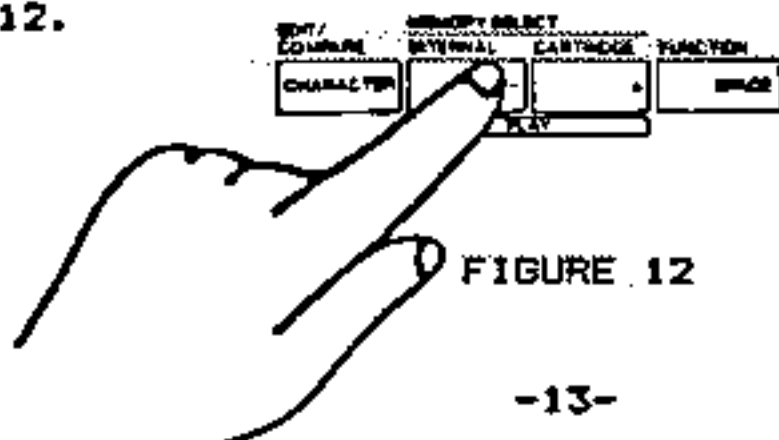

FIGURE 12

(3) Press the appropriate MEMORY SWITCH of the desired voice.

For example, to TRANSMIT the VOICE PARAMETERS of the VOICE selected by MEMORY SWITCH #1, you simply set the MIDI SYSTEM INFORMATION FUNCTION to the "ON" condition, press the INTERNAL MEMORY SELECT SWITCH, then press MEMORY SWITCH #1.

Like the MIDI CHANNEL INFORMATION FUNCTION, the MIDI SYSTEM INFORMATION FUNCTION is a GLOBAL FUNCTION. Therefore, with the MIDI SYSTEM INFORMATION FUNCTION set to the "ON" condition and you enter and remain in the INTERNAL MEMORY SELECT MODE, each time you press a MEMORY SWITCH you TRANSMIT the VOICE PARAMETERS for that memory location. You can also TRANSMIT VOICE PARAMETERS of a SINGLE CARTRIDGE VOICE by pressing the CARTRIDGE SELECT SWITCH (next to the INTERNAL SELECT SWITCH) and then press the appropriate MEMORY SWITCH.

To TRANSMIT all 32 INTERNAL MEMORY VOICE PARAMETERS, set the MIDI SYSTEM INFORMATION FUNCTION to the "ON" condition as described before. Once the MIDI SYSTEM INFORMATION is set to the "ON" condition, press the MEMORY SWITCH #8 again and then the LCD display will prompt you with the following message:

FUNCTION CONTROL  
MIDI Transmit ?

Pressing the YES/+1/ON SWITCH activates the MIDI TRANSMISSION of all 32 INTERNAL MEMORY VOICE PARAMETERS.

MEMORY SWITCH #8 - FUNCTION #3, FC VOLUME INFORMATION ON/OFF

As you may recall the FC (FOOT CONTROLLER) VOLUME INFORMATION ON/OFF FUNCTION allows you to utilize the Foot Controller pedal in conjunction with the MODULATION FOOT CONTROLLER INPUT to TRANSMIT VOLUME INFORMATION from the MIDI OUTPUT. Therefore, you may want to connect an FC3 or FC7 Foot Controller pedal as you go through the description of this FUNCTION.

The FC VOLUME INFORMATION ON/OFF FUNCTION is selected in one of two ways depending upon the condition of the MIDI SYSTEM INFORMATION FUNCTION. While still in the FUNCTION MODE, if the MIDI SYSTEM INFORMATION FUNCTION is set to the "OFF" condition, then the FC VOLUME INFORMATION ON/OFF FUNCTION is selected by pressing MEMORY SWITCH #8 three times when starting from the initial display of;

FUNCTION CONTROL  
Midi Ch Info\*\*\*

(where \*\*\* represents the ON or OFF condition).

REMEMBER THIS FUNCTION (MIDI CHANNEL INFORMATION ON/OFF) IS DISPLAY WHEN YOU PRESS MEMORY SWITCH #8 FOR THE FIRST TIME.



If the MIDI SYSTEM INFORMATION FUNCTION is set to the "ON" condition, then the FC VOLUME INFORMATION ON/OFF FUNCTION is selected by pressing the MEMORY SWITCH #8 four times when starting from the initial MIDI CHANNEL INFORMATION display. Once the FC VOLUME INFORMATION FUNCTION is selected, the LCD Display will indicate the FUNCTION and the condition (whether ON or OFF). Shown below is an example of the LCD Display when the FUNCTION is set to the "OFF" condition:

FUNCTION CONTROL  
FC --> Volume:OFF

Under these conditions, pressing the YES/+1/ON SWITCH or moving the DATA ENTRY SLIDER to its MAXIMUM position will set the FC VOLUME INFORMATION FUNCTION to the "ON" condition. The LCD Display will then indicate the FUNCTION has been set to the "ON" condition as shown below:

FUNCTION CONTROL  
FC --> Volume:ON

You can set the FUNCTION back to the previous "OFF" condition by pressing the NO/-1/OFF SWITCH or moving the DATA ENTRY SLIDER to the MINIMUM position.

FIGURES 13A and 13B show diagrams of the TRANSMIT and RECEIVE characteristics when the FC VOLUME INFORMATION FUNCTION is set to the OFF condition. The FC VOLUME INFORMATION FUNCTION is a TRANSMIT FUNCTION. In the OFF condition the DX7 will TRANSMIT FOOT CONTROLLER (FC) MODULATION INFORMATION provided the MIDI CHANNEL INFORMATION FUNCTION is set to the "ON" condition. In the RECEIVE MODE, even with the FC VOLUME INFORMATION FUNCTION set to the "OFF" condition the DX7 will still RECEIVE both FC MODULATION and VOLUME INFORMATION, once again, provided the MIDI CHANNEL INFORMATION FUNCTION is set to the "ON" condition.

TRANSMIT CHARACTERISTICS WHEN FC VOLUME INFORMATION FUNCTION IS OFF

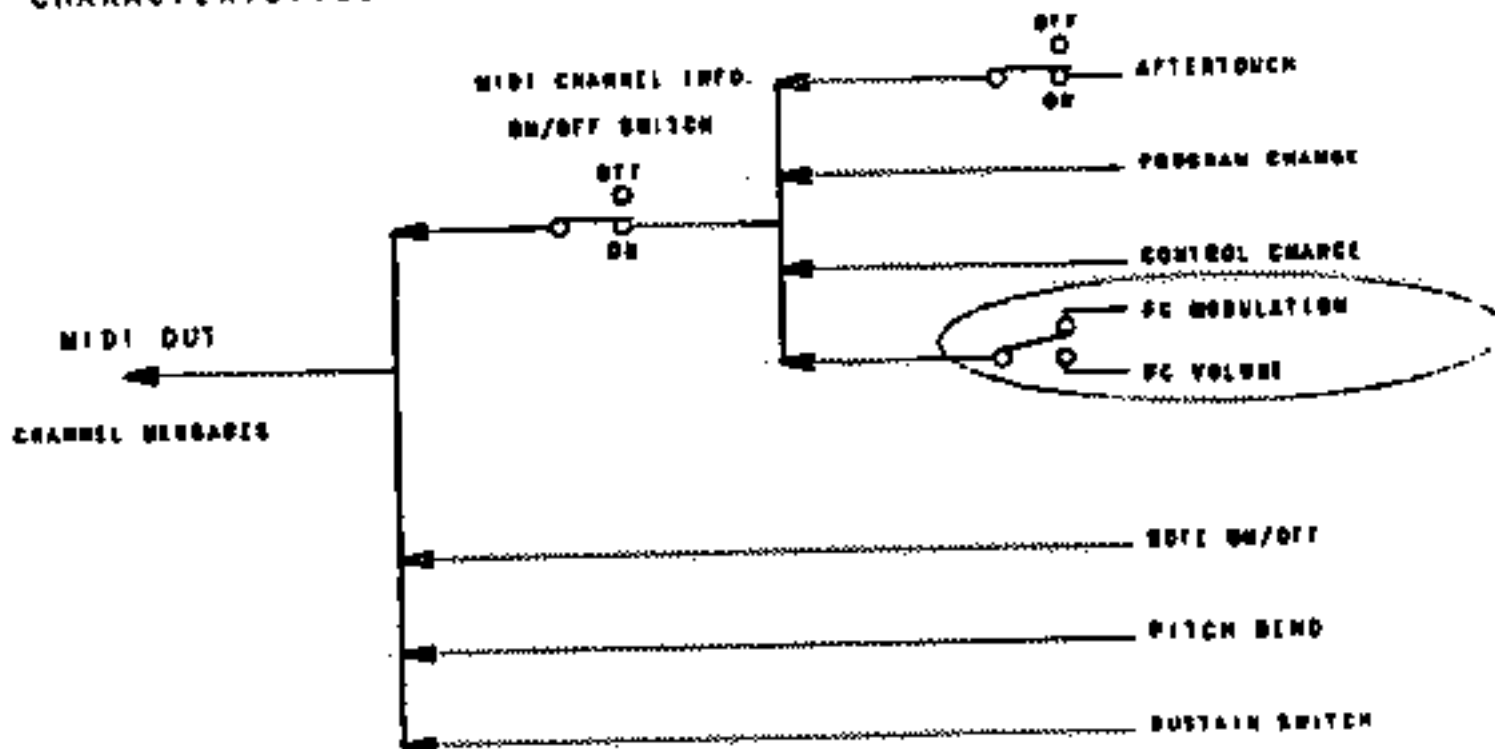

FIGURE 13A

RECEIVE CHARACTERISTICS WHEN FC VOLUME INFORMATION FUNCTION IS OFF

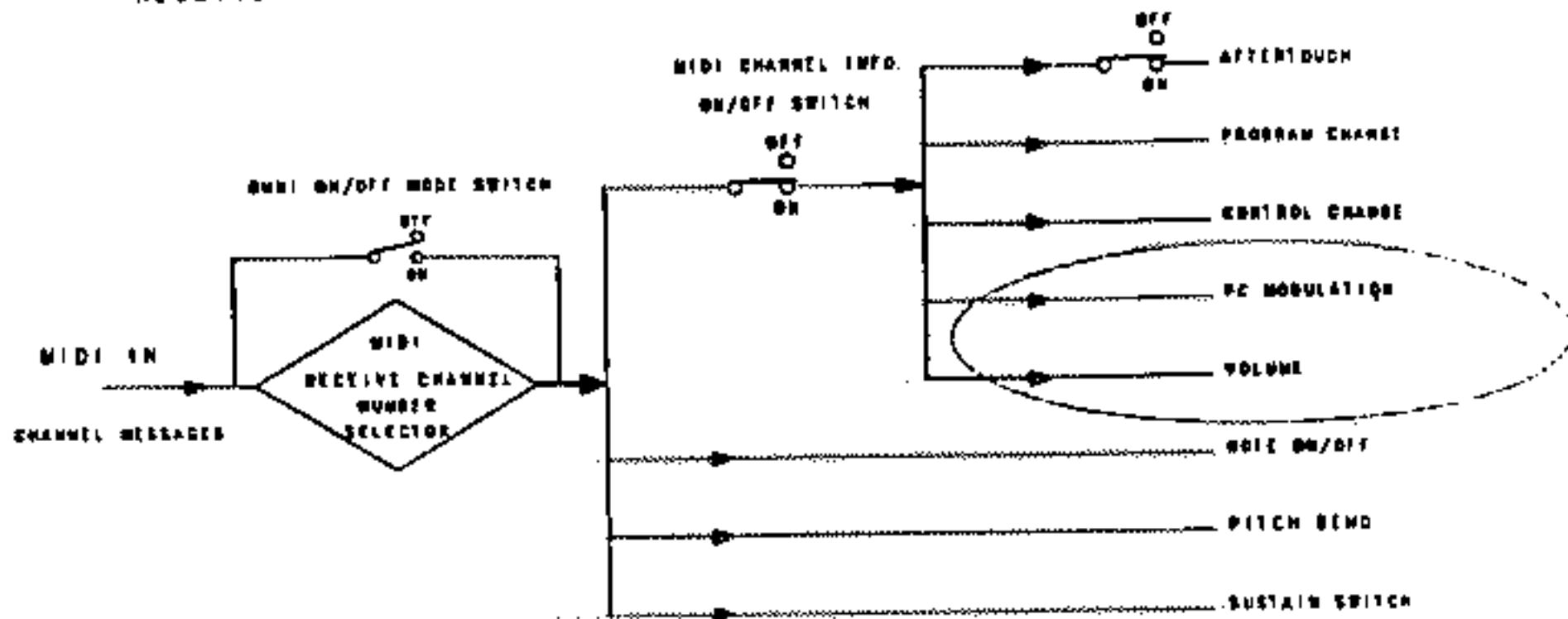

FIGURE 13B

FIGURE 14 shows the TRANSMIT characteristics diagram when the FC VOLUME INFORMATION FUNCTION is set to the "ON" condition. When this FUNCTION is "ON", the FC VOLUME INFORMATION can be TRANSMITTED. The RECEIVE characteristics are the same as those shown in FIGURE 13B. The standard VOLUME INFORMATION and FC MODULATION INFORMATION can both be RECEIVED when the FC VOLUME INFORMATION FUNCTION is "ON". Naturally the MIDI CHANNEL INFORMATION FUNCTION must also be set to the "ON" condition.

TRANSMIT CHARACTERISTICS WHEN FC VOLUME INFORMATION FUNCTION IS ON

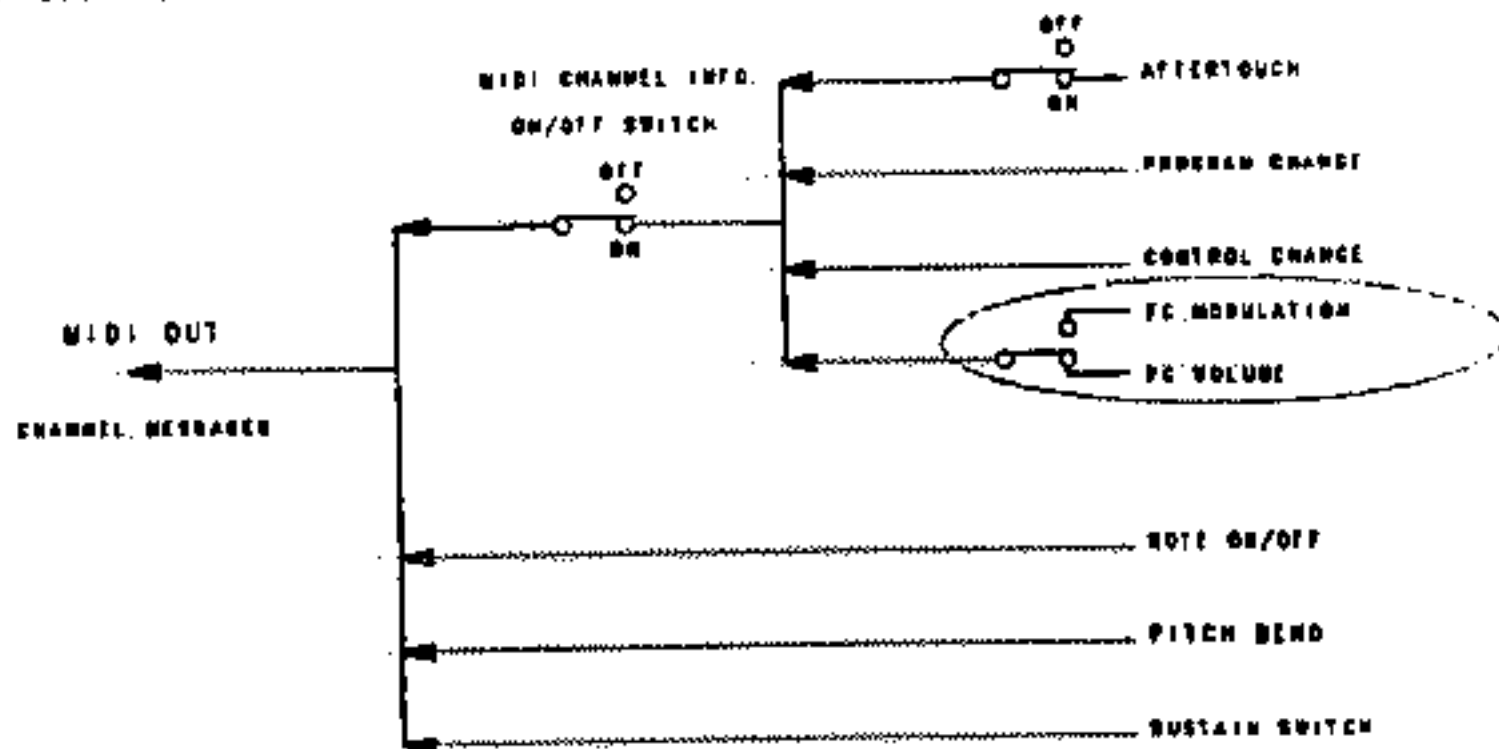

FIGURE 14

## DX7 SPECIAL EDITION ROM INSTRUCTION GUIDE

It should be noted that when you TRANSMIT VOLUME INFORMATION, the DX7's internal FOOT CONTROLLER CIRCUITRY will also respond to this VOLUME INFORMATION. In other words, if the FOOT CONTROLLER FUNCTION PARAMETERS are set-up to, for example, PITCH MODULATE the sound selected on the DX7, when you TRANSMIT VOLUME INFORMATION by way of your FOOT CONTROLLER pedal you will also PITCH MODULATE the sound of the DX7. Since the FC VOLUME FUNCTION and the FOOT CONTROLLER FUNCTIONS of the SPECIAL EDITION ROM can be memorized per voice, you can customize the conditions and FUNCTIONS that you want to have occur for each voice.

One other thing to note is that if you want to TRANSMIT FC VOLUME INFORMATION and also control the VOLUME of the DX7 itself then you will need two Foot Controller Pedals. One will be plugged into the VOLUME Pedal Input to control the VOLUME of the DX7 and the other Pedal will be plugged into the MODULATION Input in order to TRANSMIT VOLUME INFORMATION from the MIDI OUT connector.

### MEMORY SWITCH #8 - FUNCTION #4, AFTERTOUCH INFORMATION ON/OFF

The AFTERTOUCH INFORMATION ON/OFF FUNCTION allows you to select whether or not you want to TRANSMIT AFTERTOUCH INFORMATION. This FUNCTION is also programmable per VOICE.

The AFTERTOUCH INFORMATION ON/OFF FUNCTION is activated in one of two ways depending upon the condition of the MIDI SYSTEM INFORMATION FUNCTION. While still in the FUNCTION MODE, if the MIDI SYSTEM INFORMATION FUNCTION is set to the "OFF" condition, the AFTERTOUCH INFORMATION ON/OFF FUNCTION is selected by pressing MEMORY SWITCH #8 four times when starting from the initial display of)

FUNCTION CONTROL  
Midi Ch Info:\*\*\*

(where \*\*\* represents the ON or OFF condition).

REMEMBER THIS FUNCTION (MIDI CHANNEL INFORMATION ON/OFF) IS DISPLAY WHEN YOU PRESS MEMORY SWITCH #8 FOR THE FIRST TIME.

If the MIDI SYSTEM INFORMATION FUNCTION is set to the "ON" condition, then the AFTERTOUCH INFORMATION ON/OFF FUNCTION is selected by pressing MEMORY SWITCH #8 five times when starting from the initial MIDI CHANNEL INFORMATION display. Once the AFTERTOUCH INFORMATION FUNCTION is selected the LCD Display will indicate the FUNCTION and the condition (whether ON or OFF). Shown below is an example of the LCD Display when the FUNCTION is set to the "OFF" condition:

FUNCTION CONTROL  
Aftertouch :OFF

Under these conditions, pressing the YES/+1/ON SWITCH or moving the DATA ENTRY SLIDER to its MAXIMUM position will set the AFTERTOUCHE INFORMATION FUNCTION to the "ON" condition. The LCD Display will then indicate the FUNCTION has been set to the "ON" condition as shown below:

FUNCTION CONTROL  
Aftertouch ON

You can set the FUNCTION back to the previous "OFF" condition by pressing the NO/-1/OFF SWITCH or moving the DATA ENTRY SLIDER to the MINIMUM position.

FIGURES 15A and 15B show diagrams of the TRANSMIT and RECEIVE characteristics when the AFTERTOUCHE INFORMATION FUNCTION is set to the OFF condition. In the OFF condition the DX7 will NOT TRANSMIT AFTERTOUCHE INFORMATION. This FUNCTION is especially useful when you don't want to record AFTERTOUCHE INFORMATION into a sequencer which takes-up more of the sequencer's memory area. Even with the AFTERTOUCHE FUNCTION set to the "OFF" condition, you can still activate the DX7's internal circuit in order to have AFTERTOUCHE characteristics added to the sound of the DX7. In the RECEIVE MODE, even with the AFTERTOUCHE INFORMATION FUNCTION set to the "OFF" condition the DX7 will still RECEIVE AFTERTOUCHE INFORMATION, this is provided the MIDI CHANNEL INFORMATION FUNCTION is set to the "ON" condition.

TRANSMIT CHARACTERISTICS WHEN AFTERTOUCHE INFORMATION FUNCTION IS OFF

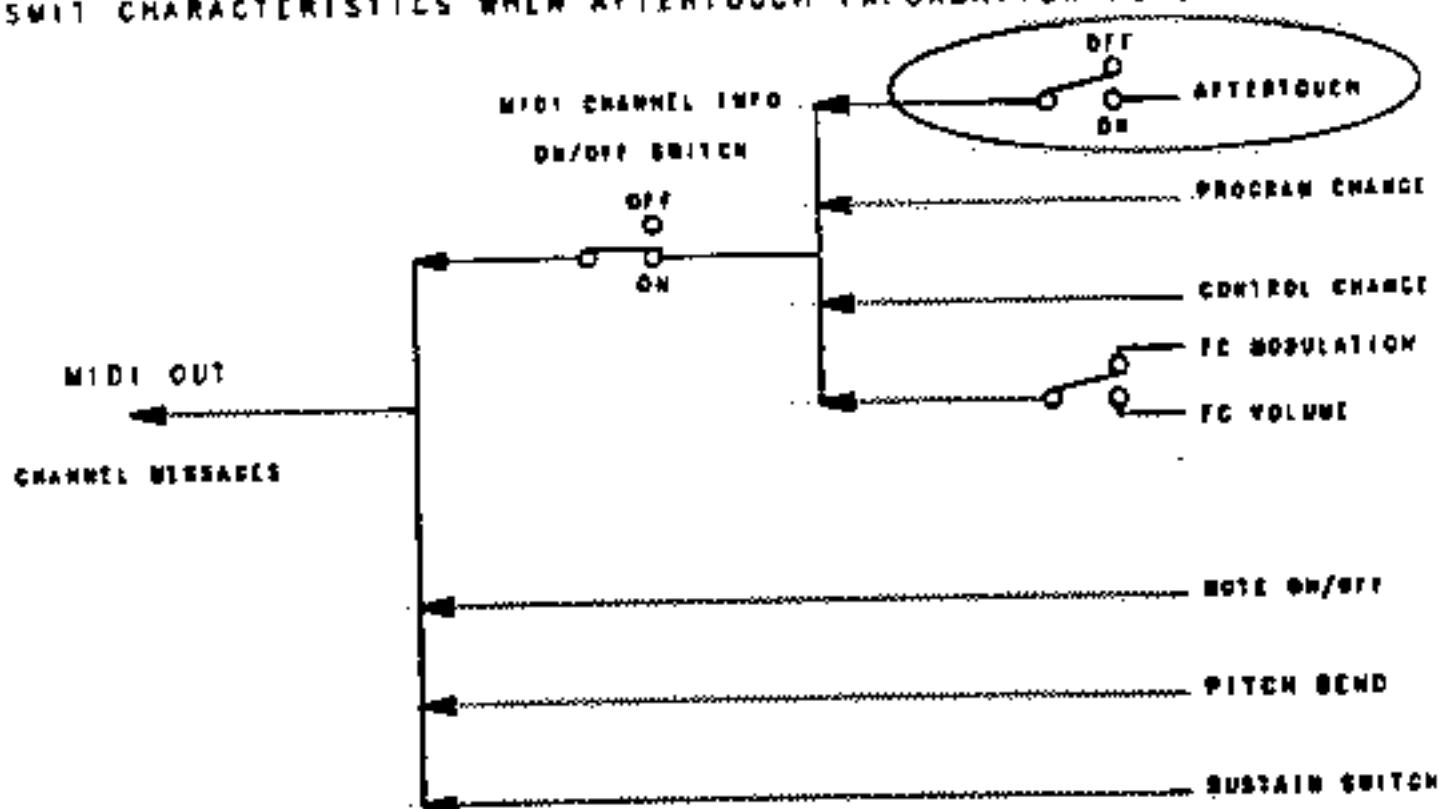

FIGURE 15A

# DX7 SPECIAL EDITION ROM INSTRUCTION GUIDE

## RECEIVE CHARACTERISTICS WHEN AFTERTOUCH INFORMATION FUNCTION IS OFF

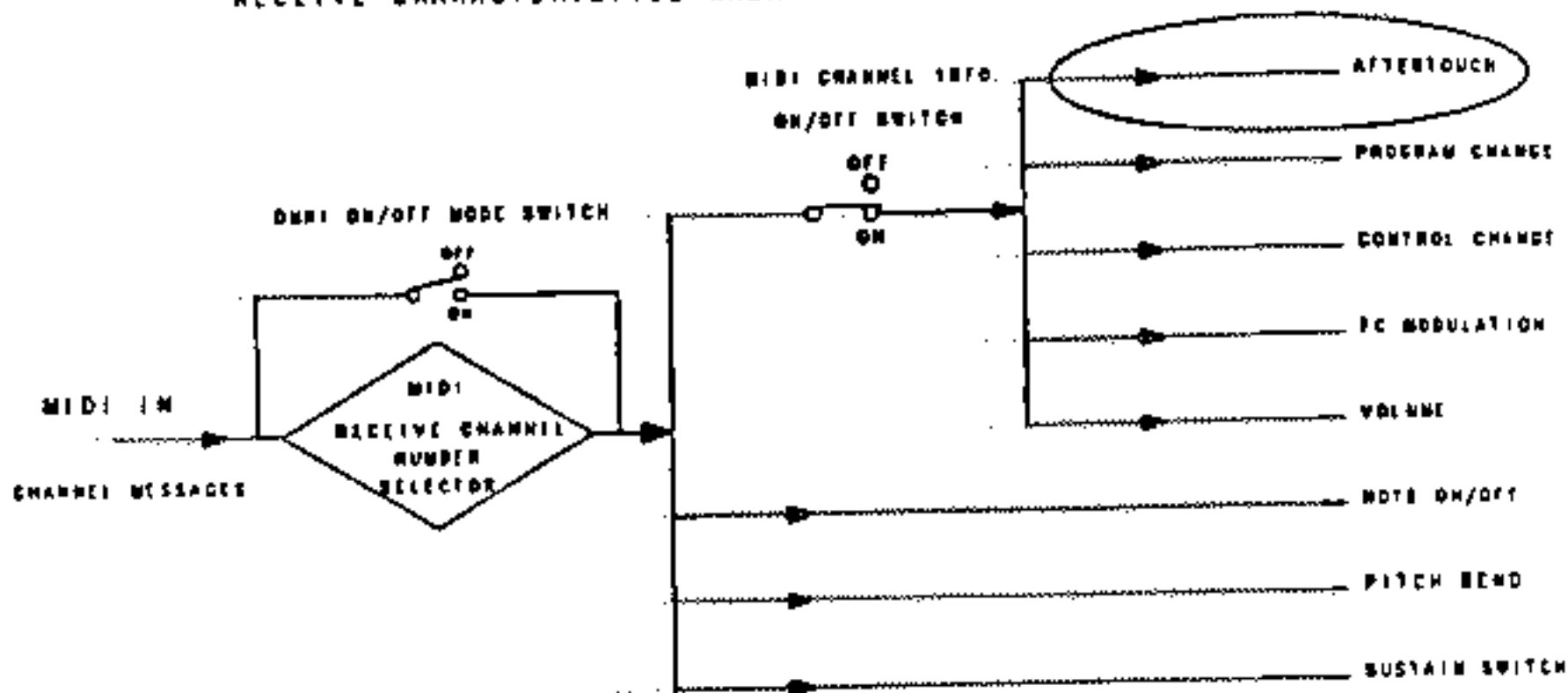

FIGURE 15B

FIGURE 16 shows the TRANSMIT characteristics diagram when the AFTERTOUCH INFORMATION FUNCTION is set to the "ON" condition. When this FUNCTION is "ON", the DX7 will TRANSMIT AFTERTOUCH INFORMATION, provided the MIDI CHANNEL INFORMATION FUNCTION is also set to the "ON" condition. The RECEIVE characteristics are the same as those shown in FIGURE 15B. In the RECEIVE MODE, when the FUNCTION is "ON", the DX7 will be able to RECEIVE AFTERTOUCH INFORMATION. Once again, this RECEIVE condition is dependent upon the MIDI CHANNEL INFORMATION FUNCTION; it must be set to the "ON" condition.

## TRANSMIT CHARACTERISTICS WHEN AFTERTOUCH INFORMATION FUNCTION IS ON

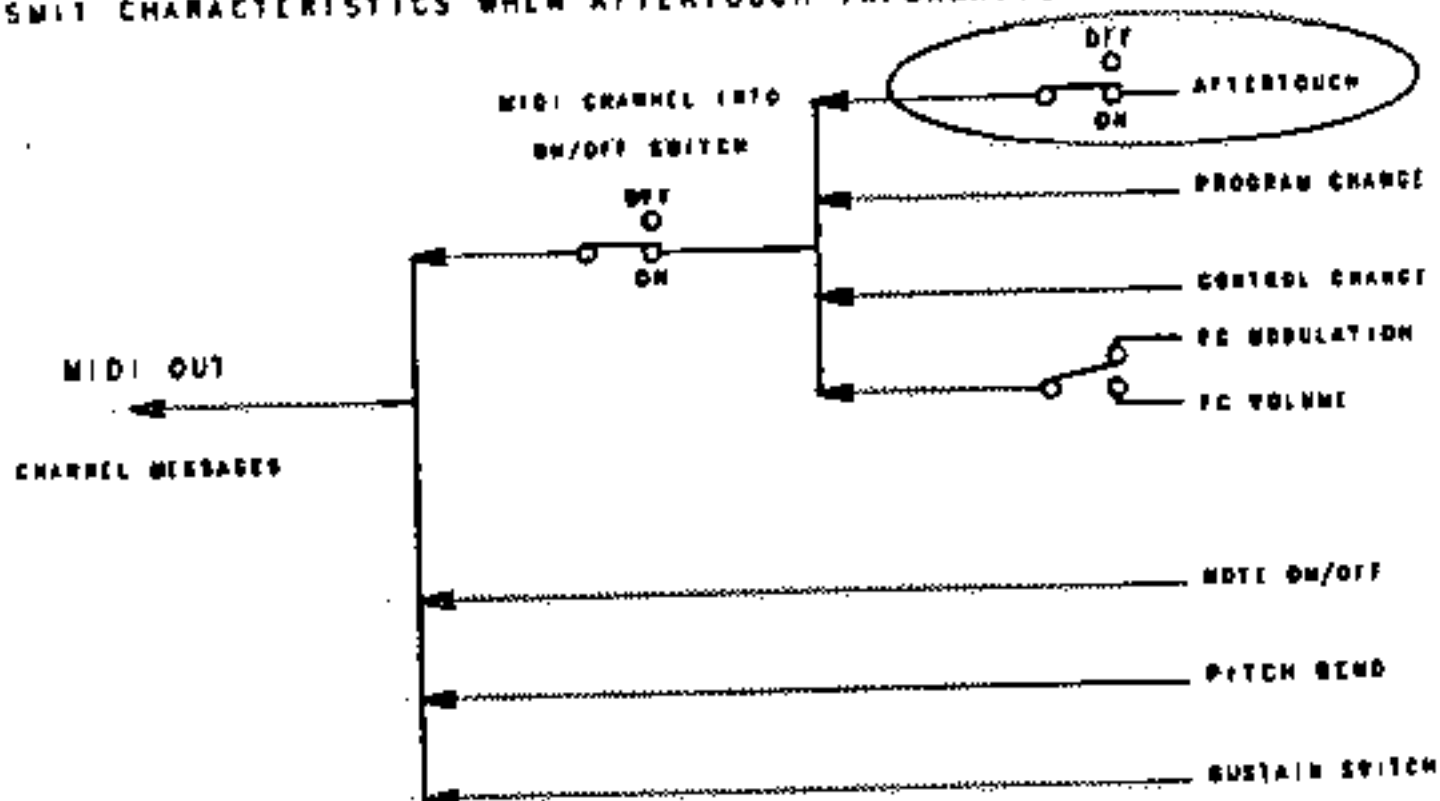

FIGURE 16

MEMORY SWITCH #10 - FUNCTION #1, VOICE INITIALIZE

The VOICE INITIALIZE FUNCTION operates in the same manner as it did before. This FUNCTION allows you to INITIALIZE or SET all the VOICE PARAMETER settings to PRESET conditions to provide a starting point for VOICE PROGRAMMING purposes. If you are still in the FUNCTION MODE, pressing the MEMORY SWITCH #10 for the first time will select the VOICE INITIALIZE FUNCTION. Remember, if you are not in the FUNCTION MODE, press the FUNCTION SWITCH to the LEFT of the LCD Display and then press MEMORY SWITCH #10. The LCD Display will indicate that you have selected the VOICE INITIALIZE FUNCTION by prompting you with the following message;

FUNCTION CONTROL  
Voice Init. ?

If you want to INITIALIZE the VOICE PARAMETER settings to PRESET conditions, press the YES/+1/ON SWITCH. The DX7 will automatically be placed in the EDIT MODE and the VOICE EDIT MEMORY or BUFFER will be INITIALIZED with PRESET VOICE PARAMETER settings. If you don't want to INITIALIZE the VOICE PARAMETERS then you can either select another FUNCTION or return to the INTERNAL VOICE SELECT MODE, by pressing the INTERNAL VOICE SELECT SWITCH and then the desired MEMORY SWITCH. Please refer to your ORIGINAL DX7 OWNER'S MANUAL for further information on this FUNCTION.

MEMORY SWITCH #10 - FUNCTION #2, SINGLE FUNCTION INITIALIZE

The SINGLE FUNCTION INITIALIZE JOB allows you to INITIALIZE or SET all FUNCTION PARAMETERS to PRESET conditions for a Single Voice. This provides you with a starting point for programming FUNCTION PARAMETERS. If you are still in the FUNCTION MODE, you can select this JOB or FUNCTION by pressing MEMORY SWITCH #10 a second time. If you are not in the FUNCTION MODE, press the FUNCTION SWITCH and then press MEMORY SWITCH #10 twice. The LCD Display will indicate that you have selected the SINGLE FUNCTION INITIALIZE JOB by prompting you with the following message;

FUNCTION CONTROL  
Sgl Func Init. ?

If you want to INITIALIZE the FUNCTION PARAMETER settings for a Single Voice then press the YES/+1/ON SWITCH. The LCD Display responds with the message;

FUNCTION CONTROL  
Are You Sure ?

By pressing the YES/+1/ON SWITCH again the DX7 will automatically store the VOICE PARAMETERS of the selected VOICE into the VOICE EDIT MEMORY or BUFFER with no changes in VOICE PARAMETER settings. However, the area of the EDIT MEMORY or BUFFER that holds FUNCTION PARAMETER settings will be INITIALIZED to PRESET

FUNCTION conditions. The LCD Display will indicate the SINGLE FUNCTION INITIALIZE JOB is finished by displaying the message:

FUNCTION CONTROL  
COMPLETED

The PRESET FUNCTION PARAMETER settings are listed in the INITIALIZED FUNCTION PARAMETER CHART of APPENDIX C on PAGE 41. The PRESET FUNCTION PARAMETER settings are NOT saved to the specific VOICE that you selected to FUNCTION EDIT until you manually store them back. This will allow you to EDIT particular FUNCTION PARAMETERS while the others remain at their PRESET conditions. Once you have EDITED the PARAMETERS that you wanted, then you can store the VOICE along with its FUNCTION PARAMETERS from the EDIT BUFFER to the desired MEMORY location. If you want to change the name of the VOICE before storing it back, you would have to press the EDIT/COMPARE SWITCH and the VOICE NAME parameter (MEMORY SWITCH #32). For example, referring to FIGURE 17, if you selected the VOICE stored at MEMORY SWITCH #1, when you implement the SINGLE FUNCTION INITIALIZE JOB two things would happen. (1) The VOICE PARAMETERS are RECALLED to the VOICE EDIT BUFFER area, and (2) The PRESET FUNCTION PARAMETER settings are INITIALIZED or SAVED to the FUNCTION area of the EDIT BUFFER.

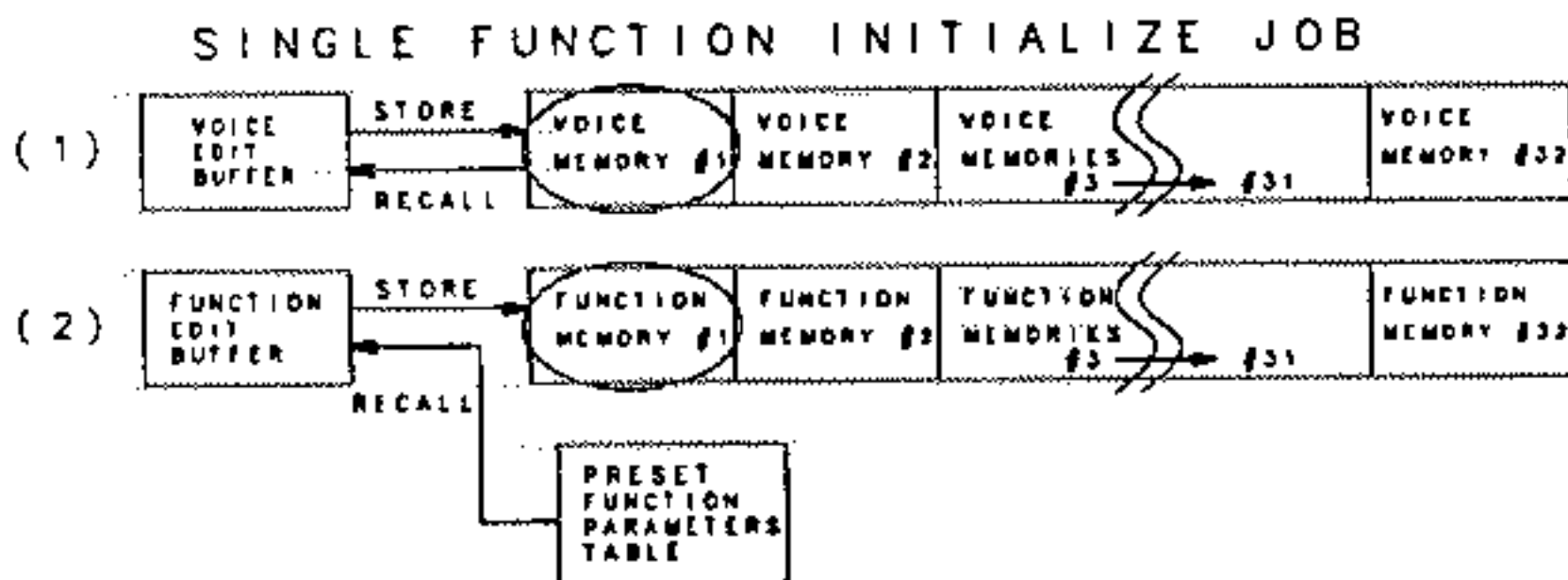

FIGURE 17

If you have EDITED all the PARAMETERS that you wanted then you can STORE the VOICE along with its FUNCTION PARAMETER settings by following the procedure given below:

- (1) Check to see if the INTERNAL MEMORY PROTECT parameter is switched "OFF" by pressing the INTERNAL MEMORY PROTECT SWITCH located to the LEFT of the LCD Display, the upper row, and next to the STORE SWITCH. If this PROTECT parameter is "ON", then simply press the NO-/1/OFF SWITCH to turn INTERNAL MEMORY PROTECT "OFF".
- (2) With MEMORY PROTECT "OFF", press the INTERNAL MEMORY SELECT SWITCH just below the MEMORY PROTECT SWITCH to return to the MEMORY SELECT MODE.

- (3) While pressing and holding the STORE SWITCH, press the desired MEMORY SWITCH in order to store the VOICE and FUNCTION PARAMETERS to that location.

If you don't want to INITIALIZE the FUNCTION PARAMETERS then you can either select another FUNCTION or return to the INTERNAL VOICE SELECT MODE, by pressing the INTERNAL VOICE SELECT SWITCH and then the desired MEMORY SWITCH.

MEMORY SWITCH #10 - FUNCTION #3, ALL FUNCTION INITIALIZE

The ALL FUNCTION INITIALIZE JOB allows you to INITIALIZE or SET all FUNCTION PARAMETERS to PRESET conditions for all of the 32 INTERNAL VOICE MEMORY locations. This provides you with a starting point for programming FUNCTION PARAMETERS for all 32 VOICES. IT SHOULD BE NOTED THAT THIS FUNCTION DOES NOT WORK LIKE THE SINGLE FUNCTION INITIALIZE JOB. AS SOON AS YOU ACTIVATE THIS FUNCTION IT WILL STORE THE PRESET FUNCTION PARAMETER SETTINGS TO THE FUNCTION MEMORY AREA OF EACH OF THE 32 VOICE MEMORY LOCATIONS AS SHOWN IN FIGURE 10. THEREFORE, ANY PREVIOUS FUNCTION PARAMETER SETTINGS WILL BE WRITTEN OVER OR REPLACE BY THE PRESET FUNCTION PARAMETER SETTINGS. Normally you would use this FUNCTION when you have loaded a new group of 32 VOICES that have no FUNCTION PARAMETER settings memorized.

ALL FUNCTION INITIALIZE JOB

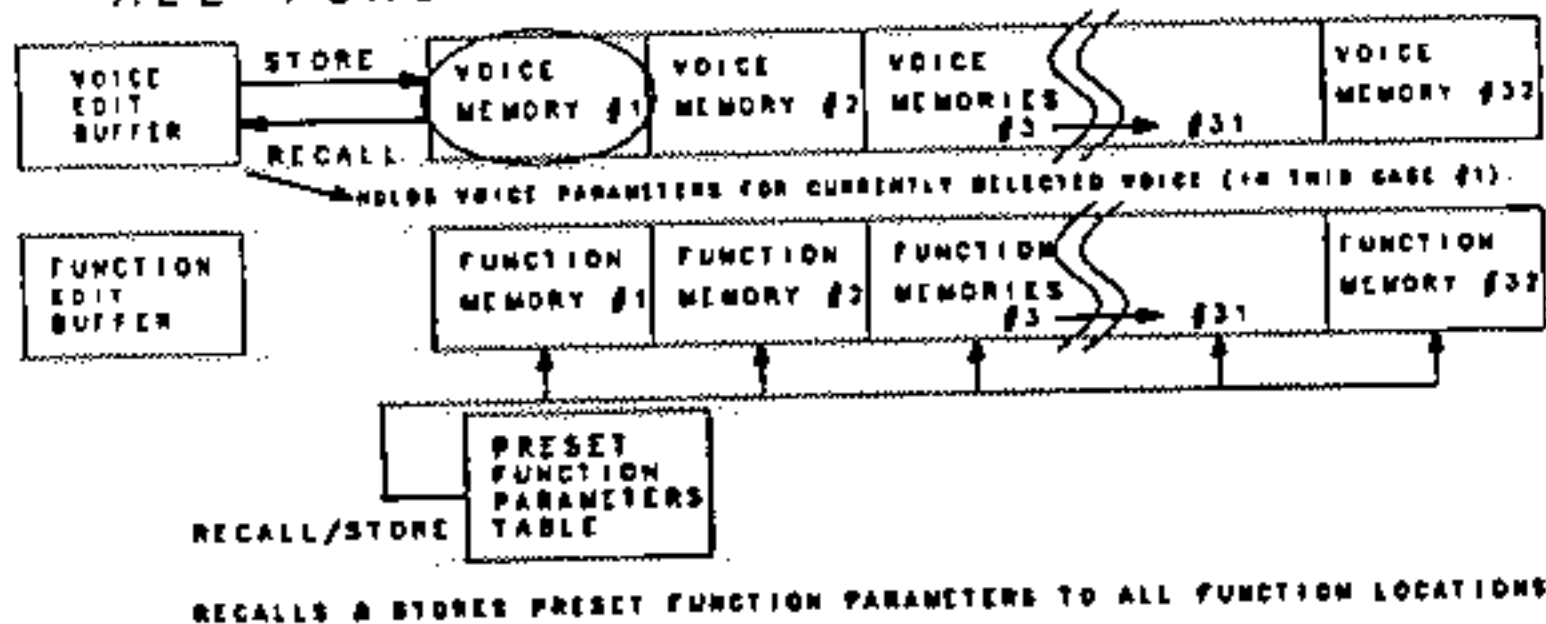

FIGURE 10

In order to implement this JOB or FUNCTION, when still in the FUNCTION MODE, simply press MEMORY SWITCH #10 a third time. If you are not in the FUNCTION MODE, press the FUNCTION SWITCH and then press MEMORY SWITCH #10 three times. The LCD Display will indicate that you have selected the ALL FUNCTION INITIALIZE JOB by prompting you with the following message:

FUNCTION CONTROL  
All Func Init. ?



Remember activating this FUNCTION will replace any previous FUNCTION PARAMETER SETTINGS with the PRESET FUNCTION PARAMETER SETTINGS. To INITIALIZE the PRESET FUNCTION PARAMETER settings to ALL FUNCTION MEMORY locations press the YES/+1/ON SWITCH. The LCD Display responds with the message;

FUNCTION CONTROL  
Are You Sure ?

By pressing the YES/+1/ON SWITCH again, the DX7 will automatically INITIALIZE the FUNCTION PARAMETER settings of each of the 32 INTERNAL FUNCTION MEMORY areas to PRESET conditions. The LCD Display will indicate the ALL FUNCTION INITIALIZE JOB is finished by displaying the message;

FUNCTION CONTROL  
COMPLETED

Now when you select any INTERNAL VOICE MEMORY location the FUNCTION PARAMETERS will be set to the PRESET conditions.

MEMORY SWITCH #12 - MIDI RECEIVE FUNCTION

The MIDI RECEIVE FUNCTION allows you to set the MIDI RECEIVE CHANNEL of the DX7 to the OMNI ON MODE or any one of 16 different MIDI channels, 1 through 16. The OMNI ON MODE will allow the DX7 to receive all incoming MIDI information, regardless of the MIDI channel number.

To select this FUNCTION, if you are still in the FUNCTION MODE simply press MEMORY SWITCH #12. If you are not in the FUNCTION MODE press the FUNCTION MODE SWITCH to the LEFT of the LCD Display and then press MEMORY SWITCH #12. In either case the LCD Display will indicate the MIDI RECEIVE FUNCTION by displaying the one of two messages;

FUNCTION CONTROL  
Midi Omni ON

or

FUNCTION CONTROL  
Midi Recv Ch \* \*

(WHERE \* = THE MIDI CHANNEL NUMBER)

You can now select the MIDI RECEIVE FUNCTION to either the OMNI ON MODE or any one of 16 MIDI CHANNELS by using either the DATA ENTRY SLIDER or the YES/+1/ON and NO/-1/OFF SWITCHES. With the DATA ENTRY SLIDER set to the MINIMUM position the MIDI RECEIVE FUNCTION will be set to the OMNI ON MODE. As you move the DATA ENTRY SLIDER towards the MAXIMUM position the LCD Display will indicate the MIDI RECEIVE CHANNEL setting. When the DATA ENTRY SLIDER is at its MAXIMUM position, the MIDI RECEIVE CHANNEL is set to RECEIVE MIDI INFORMATION on CHANNEL NUMBER 16. You can also DECREMENT the MIDI RECEIVE CHANNEL numbers by moving the DATA ENTRY SLIDER down towards the MINIMUM position. The YES/+1/ON and NO/-1/OFF SWITCHES can be used to INCREMENT or

DECREMENT the OMNI DN or MIDI RECEIVE CHANNEL settings. Using the YES/+1/DN SWITCH will INCREMENT the MIDI RECEIVE CHANNEL setting by 1 each time you press the switch. Utilizing the NO/-1/OFF SWITCH will DECREMENT the MIDI RECEIVE CHANNEL setting by 1 each time you press the switch. You may want to use the DATA ENTRY SLIDER as a COURSE adjustment and then use the YES/+1/DN and NO/-1/OFF SWITCHES as a FINE adjustment when selecting the MIDI RECEIVE MODE or CHANNEL NUMBER.

The MIDI RECEIVE FUNCTION is a GLOBAL FUNCTION. In other words, it is not a FUNCTION PARAMETER that is programmable per voice. When you select the particular condition, for example setting the MIDI RECEIVE CHANNEL to CHANNEL 6, then it allows the INSTRUMENT to RECEIVE MIDI MESSAGES on CHANNEL 6 regardless of what VOICE has been selected.

### MEMORY SWITCH #13 - MIDI TRANSMIT FUNCTION

The MIDI TRANSMIT FUNCTION allows you to set the MIDI TRANSMIT CHANNEL of the DX7 to any one of 16 different MIDI channels, 1 through 16.

To select this FUNCTION, if you are still in the FUNCTION MODE simply press MEMORY SWITCH #13. If you are not in the FUNCTION MODE press the FUNCTION MODE SWITCH to the LEFT of the LCD Display and then press MEMORY SWITCH #13. In either case the LCD Display will indicate the MIDI TRANSMIT FUNCTION by displaying the message:

FUNCTION CONTROL  
Midi Trns Ch \* \*

(WHERE \* = THE MIDI CHANNEL NUMBER)

You can now select the MIDI TRANSMIT FUNCTION to any one of 16 MIDI CHANNELS by using either the DATA ENTRY SLIDER or the YES/+1/DN and NO/-1/OFF SWITCHES. With the DATA ENTRY SLIDER set to the MINIMUM position, the MIDI TRANSMIT FUNCTION will be set to TRANSMIT MIDI INFORMATION from the MIDI OUT connector on MIDI TRANSMIT CHANNEL NUMBER 1. As you move the DATA ENTRY SLIDER towards the MAXIMUM position, the LCD Display will indicate the MIDI TRANSMIT CHANNEL setting. When the DATA ENTRY SLIDER is at its MAXIMUM position, the MIDI TRANSMIT CHANNEL is set to TRANSMIT MIDI INFORMATION on CHANNEL NUMBER 16. You can also DECREMENT the MIDI TRANSMIT CHANNEL numbers by moving the DATA ENTRY SLIDER down towards the MINIMUM position. The YES/+1/DN and NO/-1/OFF SWITCHES can be used to INCREMENT or DECREMENT the MIDI TRANSMIT CHANNEL settings. Utilizing the YES/+1/DN SWITCH will INCREMENT the MIDI TRANSMIT CHANNEL setting by 1 each time you press the switch. Using the NO/-1/OFF SWITCH will DECREMENT the MIDI TRANSMIT CHANNEL setting by 1 each time you press the switch. Once again, you may want to use the DATA ENTRY SLIDER as

a COURSE adjustment and then use the YES/+1/DN and NO/1-/OFF SWITCHES as a FINE adjustment when selecting the MIDI TRANSMIT CHANNEL NUMBER.

OPERATIONAL PROCEDURES - FINAL NOTES

In conclusion to the OPERATIONAL PROCEDURES, there are some final points regarding other OPERATIONAL FUNCTIONS. One is in regards to the PITCH EG RATE and the other is regarding the TEST MODE.

FINAL NOTES - PITCH EG RATE

The PITCH EG RATE on the SPECIAL EDITION RDM, when set at 98 or less, works in the same manner as it does in the standard RDM. When set at 99, the pitch will start at maximum (L1) and then drop to L2.

FINAL NOTES - TEST MODE

The TEST MODE is utilized by the SERVICE TECHNICIAN and not necessarily the CUSTOMER or END USER. In order to incorporate the ENHANCED features of the SPECIAL EDITION RDM, Test 3 (THE PANEL SWITCH TEST) and Test 4 (THE KEYBOARD SWITCH CONTACT TEST) have been deleted. THIS WILL HAVE NO AFFECT OR INFLUENCE ON THE SERVICEABILITY OF THE INSTRUMENT! Both the PANEL SWITCHES and KEYBOARD SWITCH CONTACTS can be diagnosed by utilizing CONVENTIONAL TROUBLESHOOTING or TESTING PROCEDURES.

## FUNCTION JOB TABLE

THESE FUNCTIONS ARE ACTIVATED BY FIRST PRESSING THE FUNCTION MODE SWITCH AND THEN PRESSING THE APPROPRIATE MEMORY SWITCH (1 THROUGH 32).

\* INDICATES A SPECIAL EDITION ROM FUNCTION

### VOICE FUNCTIONS

- |    |  |
|----|--|
| 2  | POLY/MONO MODE SELECTION (POLY OR MONO)  |
| 3  | PITCH BEND RANGE (0 TO 99)   |
| 4  | PITCH BEND STEP (0 TO 12)  |
| 5  | PORTAMENTO MODE (KEY PITCH FOLLOW OR RETAIN WITH SUSTAIN)                      |
| 6  | GLISSANDO (ON/OFF. OFF=PORTAMENTO)   |
| 7  | PORTAMENTO TIME (0 TO 99. PORTAMENTO OR GLISSANDO TIME WHICH EVER IS SELECTED) |
| 17 | MODULATION WHEEL RANGE (0 TO 99)   |
| 18 | MODULATION WHEEL PITCH (ON/OFF)  |
| 19 | MODULATION WHEEL AMPLITUDE (ON/OFF)  |
| 20 | MODULATION WHEEL EG BIAS (ON/OFF)  |
| 21 | FOOT CONTROL RANGE (0 TO 99)   |
| 22 | FOOT CONTROL PITCH (ON/OFF)  |

## FUNCTION JOB TABLE (CONTINUED)

\* INDICATES A SPECIAL EDITION ROM FUNCTION

### VOICE FUNCTIONS (CONTINUED)

- |    |                                   |
|----|-----------------------------------|
| 23 | FOOT CONTROL AMPLITUDE (ON/OFF)   |
| 24 | FOOT CONTROL EG BIAS (ON/OFF)     |
| 25 | BREATH CONTROL RANGE (0 TO 99)    |
| 26 | BREATH CONTROL PITCH (ON/OFF)     |
| 27 | BREATH CONTROL AMPLITUDE (ON/OFF) |
| 28 | BREATH CONTROL EG BIAS (ON/OFF)   |
| 29 | AFTERTOUCH RANGE (0 TO 99)        |
| 30 | AFTERTOUCH PITCH (ON/OFF)         |
| 31 | AFTERTOUCH AMPLITUDE (ON/OFF)     |
| 32 | AFTERTOUCH EG BIAS (ON/OFF)       |

### UTILITY FUNCTIONS

- |   |  |
|---|--|
| 1 | MASTER TUNE<br>• DISPLAYS MASTER TUNE SETTING (-64 TO +63) |
| 9 | EDIT RECALL (YES/NO)                                       |

## FUNCTION JOB TABLE (CONTINUED)

\* INDICATES A SPECIAL EDITION ROM FUNCTION

### UTILITY FUNCTIONS (CONTINUED)

- |    |  |
|----|--|
| 10 | FUNCTION #1 VOICE INITIALIZE (YES/NO)<br>*FUNCTION #2 SINGLE FUNCTION INITIALIZE "<br>*FUNCTION #3 ALL FUNCTION INITIALIZE " |
| 11 | CARTRIDGE FORMAT (YES/NO)  |
| 14 | BATTERY VOLTAGE CHECK  |
| 15 | SAVE TO CARTRIDGE MEMORY (YES/NO)  |
| 16 | LOAD FROM CARTRIDGE MEMORY (YES/NO)  |

### MIDI FUNCTIONS

- |    |   |
|----|---|
| 8  | *FUNCTION #1 MIDI CHANNEL INFORMATION (ON/OFF)<br>*FUNCTION #2 MIDI SYSTEM INFORMATION (ON/OFF)<br>SUB-FUNCTION WHEN MIDI SYSTEM INFORMATION IS<br>"ON", MIDI TRANSMIT (YES/NO)<br>*FUNCTION #3 FOOT CONTROLLER VOLUME TRANSMIT<br>(ON/OFF) OFF-FOOT CONTROLLER MODULATION<br>*FUNCTION #4 AFTERTOUCH TRANSMIT (ON/OFF) |
| 12 | MIDI RECEIVE FUNCTION (*OMNI ON/OFF, OR<br>1 OF 16 MIDI CHANNELS)   |
| 13 | *MIDI TRANSMIT FUNCTION<br>(1 OF 16 MIDI CHANNELS)  |

## APPENDIX A

TWO ROM MODIFICATION INFORMATION

The following instructions are only required if your instrument utilizes two System ROM ICs. This modification will allow you to use a single ROM IC instead of 2 ROM ICs and it is only necessary for a few very early production models. Serial numbers of applicable DX7 units are numbers 2660 and below. It should be noted however, that some units may have already been modified. Remember that in order to prevent any accidental circumstances resulting in the loss of the DX7 Voices stored in its memory, you should back-up or make a copy of the Voices before performing this modification. The necessary TOOLS required for this modification are listed below:

- (1) A PHILLIPS TYPE SCREW DRIVER
- (2) A SMALL FLAT-BLADE SCREW DRIVER
- (3) A SOLDERING IRON
- (4) A SOLDER VACUUM OR SOLDER WICK
- (5) SOLDER
- (6) NEEDLE-NOSE PLIERS.

For units with two System ROM ICs (IC14 and IC15), perform the following STEPS:

- STEP 1: Before beginning, make sure the power switch is TURNED OFF and the power cord is unplugged. Also disconnect any MIDI, OUTPUT or FOOT CONTROLLER cables connected to the unit.
- STEP 2: Remove the 5 Phillips-Head screws that secure the DX7's front control panel as shown in FIGURE A1. NOTE: The screw designated with the letter "B" (located next to the power switch) is shorter than the other screws. Please make sure that this screw is used at the same location when securing the front panel after the modification is complete!

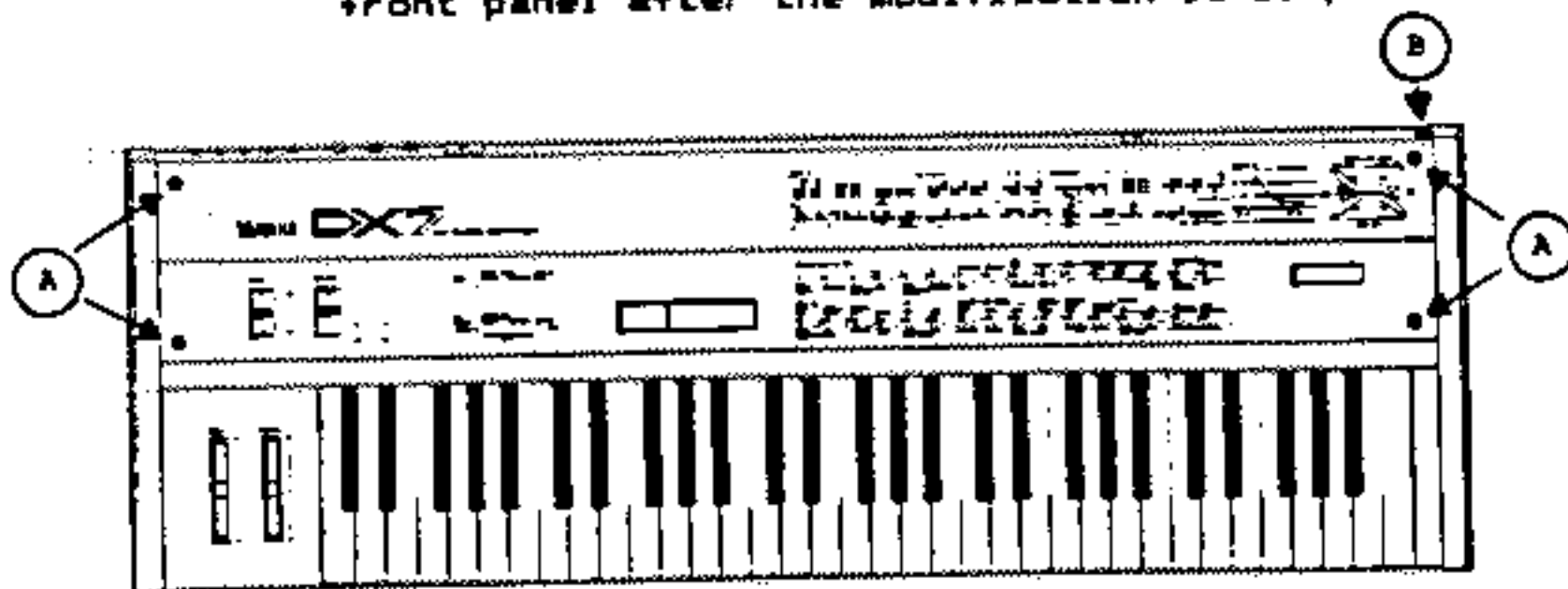

FIGURE A1

- STEP 3: Carefully lift-up the edge of the DX7's front control panel, closest to the keyboard and open it all the way until it is resting against the back edge of the DX7 case as shown in FIGURE A2.

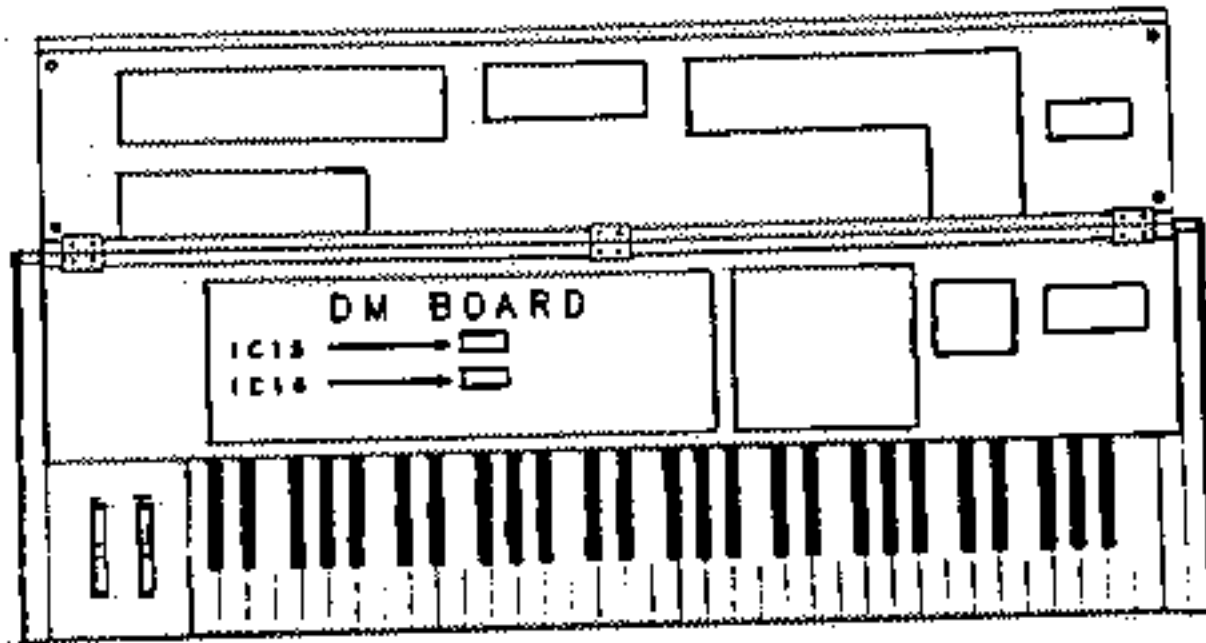

FIGURE A2

- STEP 4: Referring to FIGURE A2, locate the RDM ICs (IC14 and IC15). These RDM ICs are located near the center of the Main Circuit board (the DM board). Before removing the RDM ICs, note the direction of the notch on IC14 for future reference. Remove the IC14 and IC15 RDM ICs by utilizing the SMALL FLAT-BLADE screwdriver to carefully pry the ICs loose from their respective sockets.

- STEP 5: Locate the two 10 OHM RESISTORS between IC38 and IC27 that are shown in FIGURE A3. Using your SOLDER IRON, unsolder and move both leads of each resistor over one eyelet to the right (see FIGURE A3).

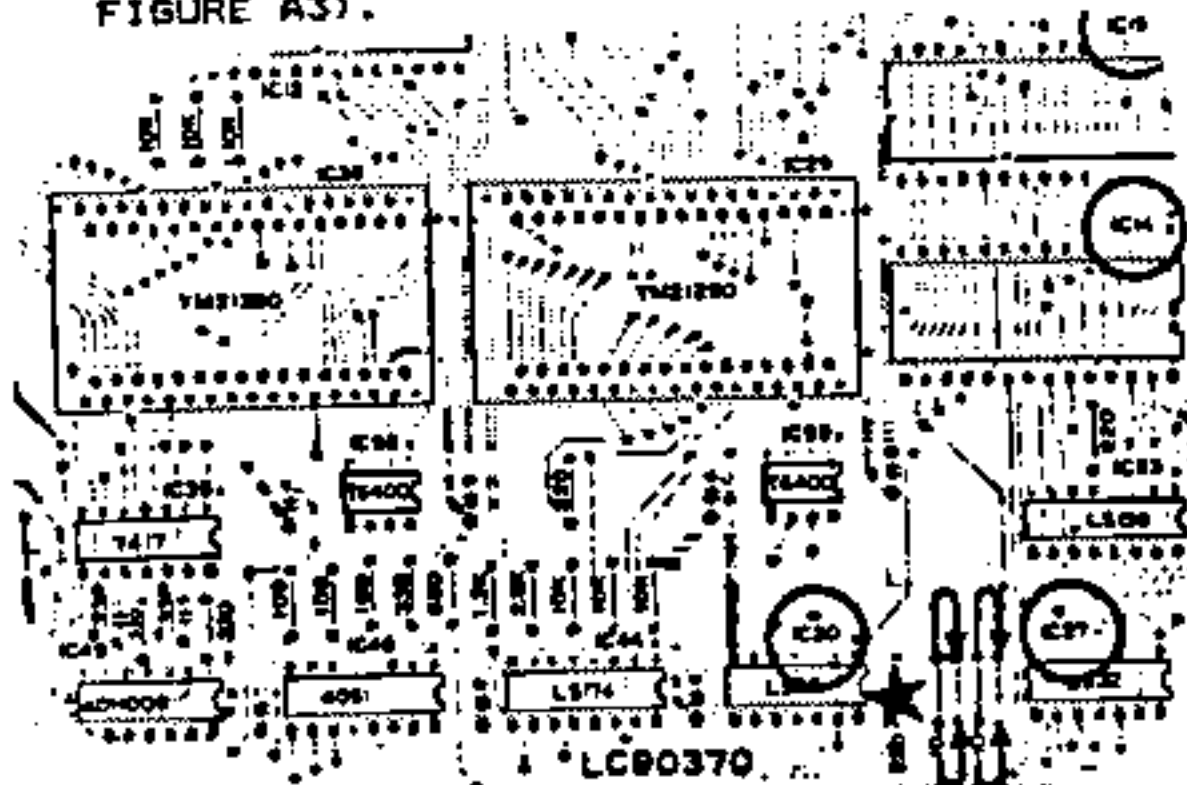

FIGURE A3



- STEP 6: Unsolder and remove IC38. Resolder the circuit pads where IC38 was removed. This is to insure proper connections of any feed-through paths.
- STEP 7: Insert the SPECIAL EDITION ROM into the IC14 socket, noting the direction of the notch. The notch of the SPECIAL EDITION ROM should face or point in the direction of the right side of the DX7 or towards the Power Supply. Also make sure the pins of the ROM are all aligned with holes of the IC14 socket. If some pins are not in the proper position for inserting, then carefully bend the pins to their proper position. Once the notch and pins of the ROM are properly positioned then carefully insert the ROM IC. Inspect your work thoroughly to make sure that no pins have been bent under or damaged during insertion.
- STEP 8: Make a quick operational test of the DX7 by closing the front control panel and plugging the power cord of the DX7 into an AC outlet. Turn on the DX7, the LCD display should initially read;

WELCOME TO DX7  
SPECIAL EDITION

The LCD display should then indicate the previous mode or condition that was last set-up on the front control panel. Make sure that you can select various voices and play the keyboard to verify that the DX7 produces a sound when an amplifier or pair of headphones is connected to the unit. If the LCD display does not indicate the above conditions or the DX7 does not produce a sound, then turn OFF the power of the DX7 and refer to the TROUBLESHOOTING SECTION found in APPENDIX B on Page 32.

APPENDIX BTROUBLESHOOTING INFORMATION

This TROUBLESHOOTING INFORMATION is provided to help you locate problems that may occur if the unit performs abnormally. However, this information contains general TROUBLESHOOTING INFORMATION and it is NOT INTENDED TO SOLVE ALL PROBLEMS. If the unit is still not functioning properly after making the follow checks, then you should take the unit to a QUALIFIED SERVICE TECHNICIAN. You may want to refer the TROUBLESHOOTING CHART that begins on Page 36 as you read through this section. You should also read this TROUBLESHOOTING INFORMATION thoroughly before proceeding with any of the checks involved.

A. VISUAL CHECK

Before turning the DX7 "ON" again, make a VISUAL CHECK of the items or components that are related to any modification of the unit. Make sure the SPECIAL EDITION ROM has been inserted properly into the socket and that no pins of the ROM have been bent under. Sometimes the pins of the ROM can be bent underneath and it will be difficult to detect this problem unless you remove the ROM to examine it. Also, if the unit was modified from a two System ROM set-up to a single System ROM set-up, go back and verify each STEP of the modification procedure. For example, make sure the two 10 OHM RESISTORS between IC30 and IC27 have been moved and soldered in the proper locations. Make sure that IC30 was removed and that the circuit pads where IC30 was removed have been resoldered to insure proper connections of any feed-through paths. If none of these Visual Checks result in fixing the problem then refer to the SYMPTOM AND PROBABLE CAUSE section.

SYMPTOM AND PROBABLE CAUSE

Using the TROUBLESHOOTING CHART, go through the following checks in order to establish and correct the problem that the unit is exhibiting. Make sure that the DX7's AC cord is plugged into an AC outlet then turn "ON" the DX7 and refer to the DISPLAY CHECK.

B. THE DISPLAY CHECK

Question 1: When you turn "ON" the DX7, does the Display come "ON"?

If the answer is NO and the Display does NOT come "ON", check to make sure that the AC cord of the DX7 is still plugged in and the power switch is "ON". If there is still no Display, you may want to try another AC outlet. However, if none of these things remedy the problem there may be a bad power supply fuse or the

power supply itself may be bad. In either case, you should take the unit to a Qualified Service Technician. **TOUCHING CERTAIN AREAS OF THE POWER SUPPLY COULD RESULT IN ELECTRICAL SHOCK!**

If the answer is YES the Display comes "ON", then proceed to Question 2.

Question 2: Does the Display appear to be working correctly?

If the answer is NO and the Display seems to work erratically or it is stuck in the initial Display setting, turn OFF the unit and then go to Question 3.

If the answer is YES and the Display seems to work correctly, go to E. THE SOUND CHECK.

Question 3: Did the DX7 need to be modified from a two System ROM set-up to a single System ROM set-up?

If the answer is NO, then go to Question 5.

If the answer is YES, then go to C. THE MODIFICATION CHECK.

C. THE MODIFICATION CHECK

Carefully go through each STEP of the modification procedure and check to make sure that each STEP was performed correctly. Once you verify each STEP of the modification procedure go to Question 4.

Question 4: Was the modification done correctly?

If the answer is NO, correct the problem and power the unit on to check the Display again.

If the answer is YES, then go Question 5.

Question 5: Was the SPECIAL EDITION ROM inserted correctly? Check to see that no pins have been bent under. **\*\*THIS CHECK MAY REQUIRE THAT YOU REMOVE THE SPECIAL EDITION ROM IN ORDER TO EXAMINE IT. NATURALLY YOU MUST TURN OFF THE POWER BEFORE REMOVING THE ROM.\*\***

If the answer is NO, correct the problem by carefully bending the pins back to the proper positions then carefully insert the ROM IC. Now turn the unit ON and go to Question 7.

If the answer to Question 5 is YES, then go to D. THE ORIGINAL ROM CHECK

D. THE ORIGINAL ROM CHECK

Turn OFF the DX7 and replace the SPECIAL EDITION ROM with the ORIGINAL ROM. (It should be noted however, that you CANNOT use the ORIGINAL ROM if your DX7 was modified for a single System ROM set-up. If this is the case, take the unit to a Qualified Service Technician.) Once you have inserted the ORIGINAL ROM, turn the unit ON and go to Question 6.

Question 6: Does the Display appear to be working correctly?

If the answer is NO, then call for Technical Assistance or take the unit to a Qualified Service Technician.

If the answer is YES, then you possibly have a bad SPECIAL EDITION ROM and you should go to E. THE SOUND CHECK in order to verify that the unit is functioning correctly. If the SPECIAL EDITION ROM appears to be at fault call for a replacement.

Question 7: Does the Display appear to be working correctly?

If the answer is NO, then go to D. THE ORIGINAL ROM CHECK.

If the answer is YES, then go to E. THE SOUND CHECK.

E. THE SOUND CHECK

Select the an Internal Voice by pressing the INTERNAL MEMORY SELECT SWITCH and any one of the 1 through 32 MEMORY SWITCHES, then go to Question 8.

Question 8: Does the Display indicate the Voice Name?

If the answer is NO, then Internal Memory may have been accidentally erased. Load Voices from a Cartridge to the Internal Memory then go to Question 9.

If the answer is YES, then go to Question 10.

Question 9: Does the Display indicate the Voice Name?

If the answer is NO, then the Internal Memory may be bad. Call for Technical Assistance or take the unit to a Qualified Service Technician.

If the answer is YES, then go to Question 10.

Question 10: Does the selected Voice sound OK?

If the answer is NO, then some of the FUNCTIONS parameters may be inadvertently set to illegal or invalid conditions.

Therefore, go through each FUNCTION beginning with the MASTER TUNE FUNCTION and check the Display. If the Display does not indicate the proper condition or has strange characters shown in the display, simply move the DATA ENTRY control to MINIMUM, then to MAXIMUM and then back to the MINIMUM setting to reset the FUNCTION. Once the FUNCTION has been reset you may wish to set it to the condition that you require then go to Question 11.

If the answer to Question 10 is YES, then the unit should be operating correctly and this ends the TROUBLESHOOTING CHECKS.

Question 11 Does the selected Voice sound OK?

If the answer is NO, then the Internal Memory may be bad. Call for Technical Assistance or take the unit to a Qualified Service Technician.

If the answer is YES, then the unit should be operating correctly and this ends the TROUBLESHOOTING CHECKS.

# TROUBLESHOOTING CHART

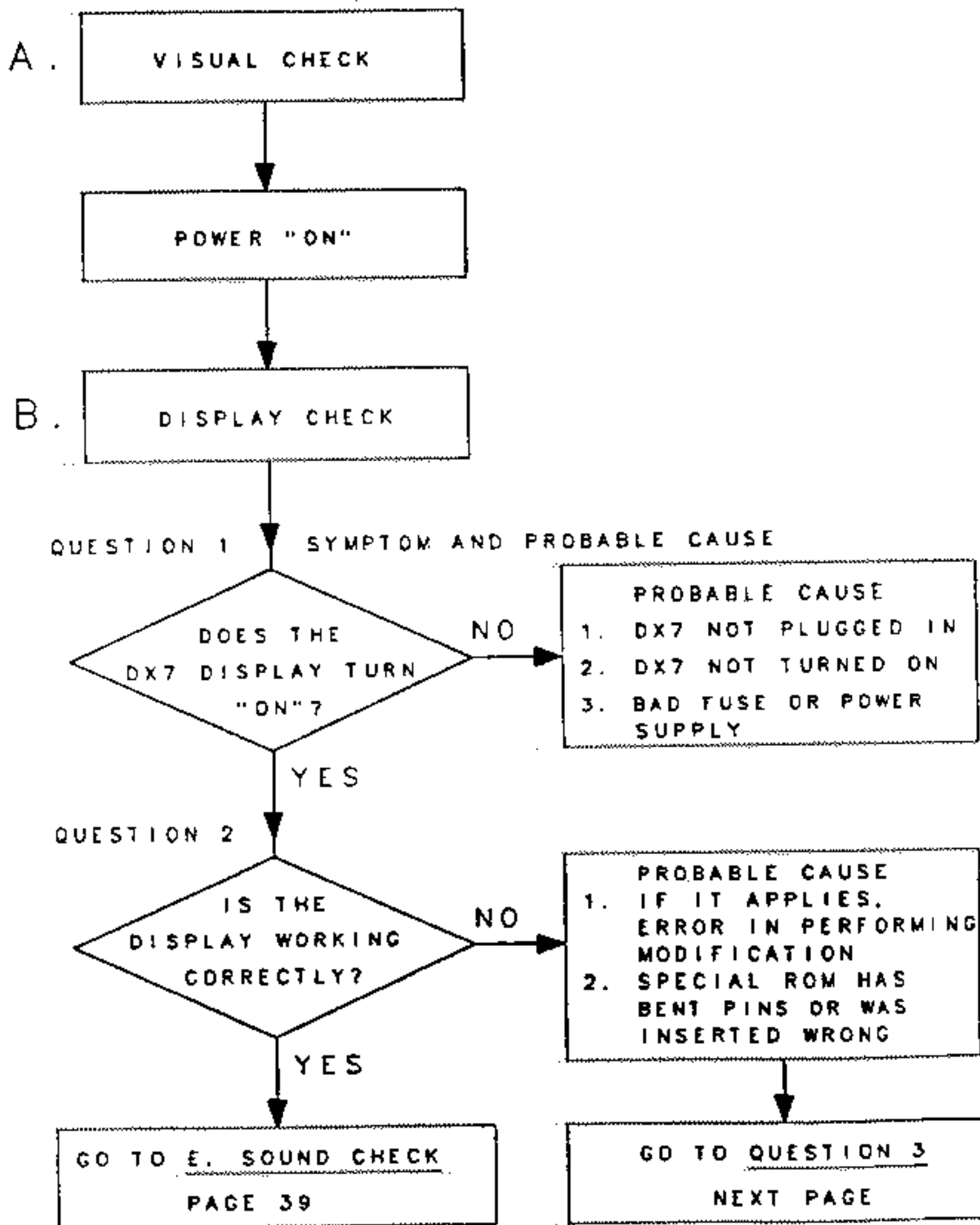

## TROUBLESHOOTING CHART (CONTINUED)

FROM PAGE 36

QUESTION 3

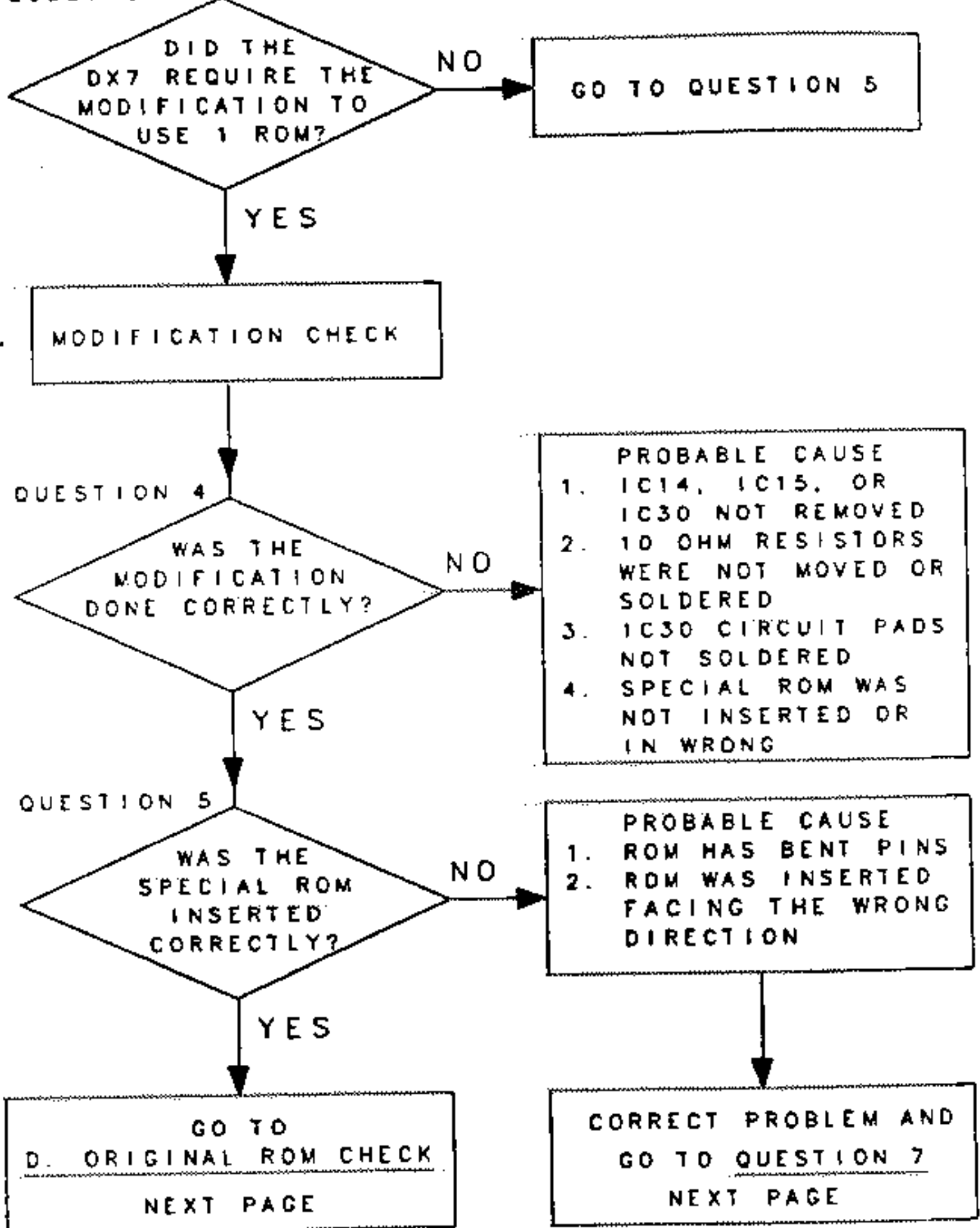

TROUBLESHOOTING CHART (CONTINUED)

FROM PAGE 37

FROM PAGE 37

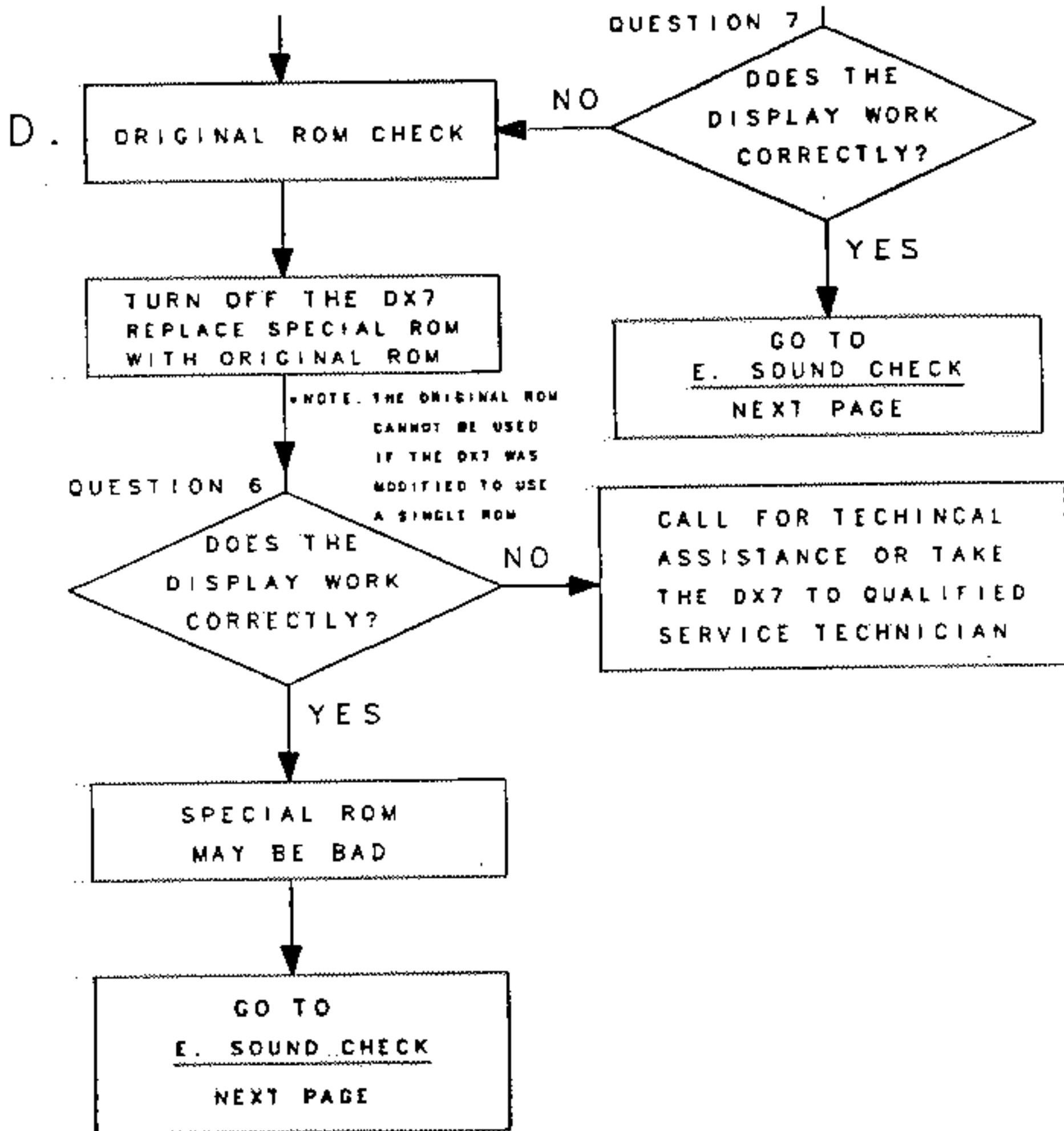



## TROUBLESHOOTING CHART (CONTINUED)

FROM PAGE 38

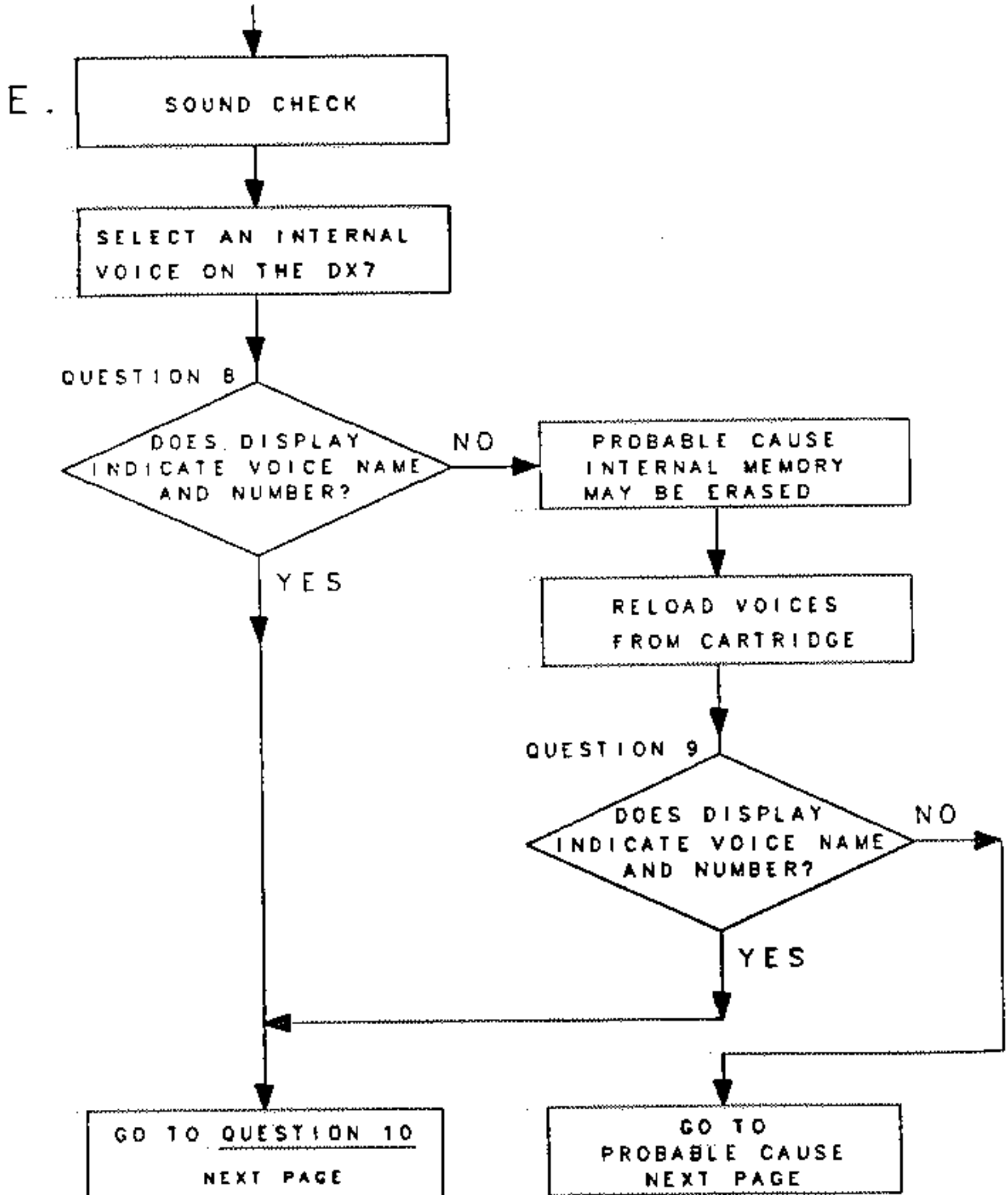

TROUBLESHOOTING CHART (CONTINUED)

FROM PAGE 39

FROM PAGE 39

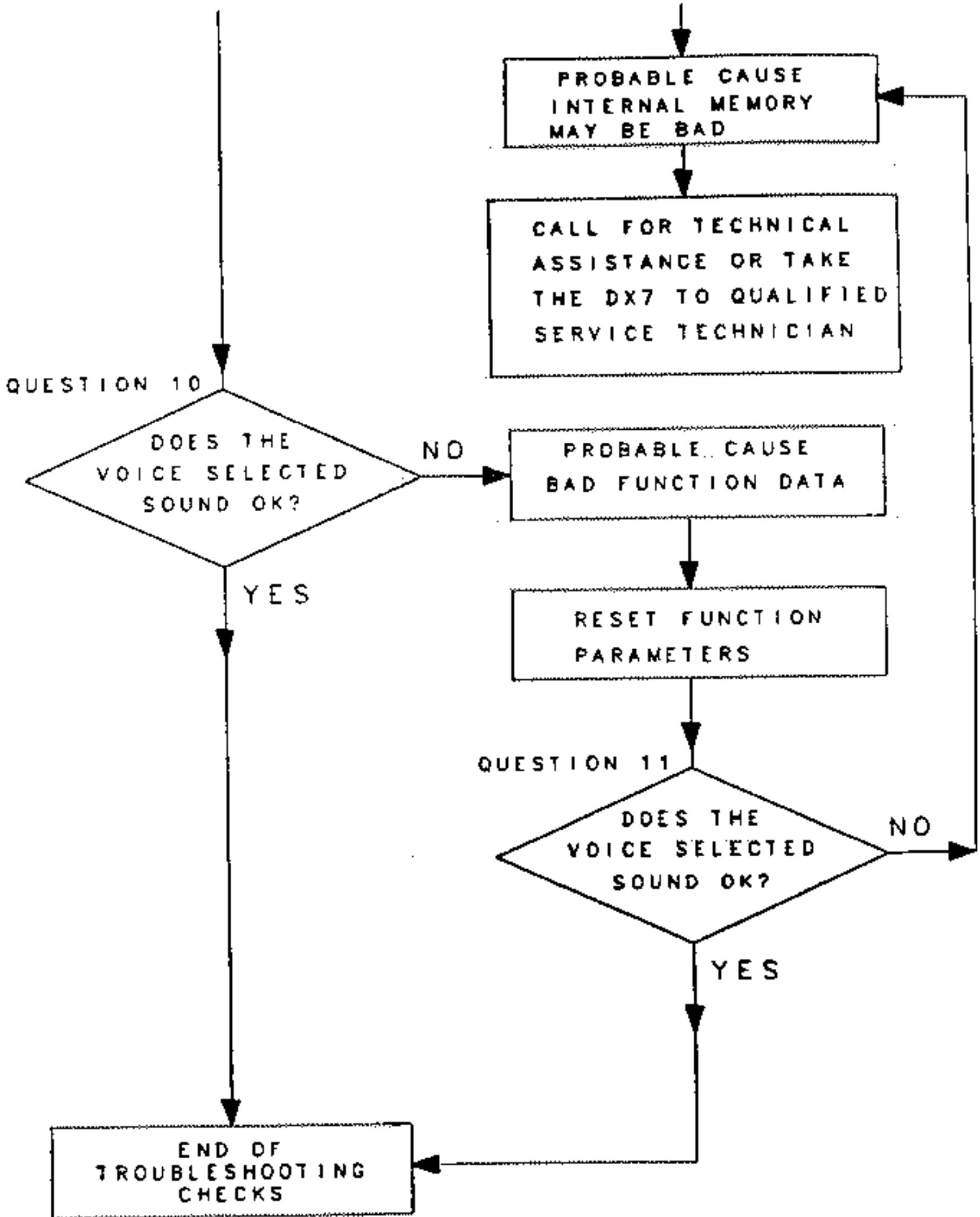

APPENDIX C

INITIALIZED FUNCTION PARAMETER CHART

\* DENOTES GLOBAL FUNCTION, NOT PROGRAMMABLE PER VOICE

\* MIDI RECEIVE CHANNEL FUNCTION  
NO CHANGE, REMAINS AT PROGRAMMED SETTING

\* MIDI TRANSMIT FUNCTION  
NO CHANGE,  
REMAINS AT PROGRAMMED SETTING

MEMORY SWITCHES

1	2	3	4	5	6	7	8	9	10	11	12	13	14	15	16
---	---	---	---	---	---	---	---	---	----	----	----	----	----	----	----

FUNCTIONS	PITCH BEND		PORTAMENTO	
	RANGE	STEP	MODE	TIME
POLY/ MONO				
POLY	3	0	RETAIN	0

\* DENOTES GLOBAL FUNCTION, NOT PROGRAMMABLE PER VOICE

\* (1) FUNCTION #1 MIDI CHANNEL INFORMATION ON/OFF  
NO CHANGE, REMAINS AT PROGRAMMED SETTING

\* (2) FUNCTION #2 MIDI SYSTEM INFORMATION ON/OFF  
NO CHANGE, REMAINS AT PROGRAMMED SETTING

(3) FUNCTION #3 FC (FOOT CONTROLLER) VOLUME ON/OFF  
INITIALIZED TO THE OFF SETTING, OFF-FC MODULATION

(4) FUNCTION #4 AFTER TOUCH TRANSMIT ON/OFF  
INITIALIZED TO THE ON SETTING

MEMORY SWITCHES

17	18	19	20	21	22	23	24	25	26	27	28	29	30	31	32
----	----	----	----	----	----	----	----	----	----	----	----	----	----	----	----

MODULATION WHEEL				FOOT CONTROL				BREATH CONTROL				AFTERTOUCH			
RANGE	PITCH	AMPLI- TUDE	CO BIAS	RANGE	PITCH	AMPLI- TUDE	ES BIAS	RANGE	PITCH	AMPLI- TUDE	ES BIAS	RANGE	PITCH	AMPLI- TUDE	ES BIAS
50	ON	OFF	OFF	0	OFF	OFF	OFF	0	OFF	OFF	OFF	0	OFF	OFF	OFF

INITIALIZED VALUES  
FUNCTIONS